

HR500

- Efficient 550m³/h heat recovery ventilation unit or high performance 900m³/h extract fan
- Lightweight, compact and easy to install
- Integral shutters on X type model
- Easy to clean
- Up to 70% heat recovery
- Controller with sensor mode, allows a range of sensors to be used in conjunction with the HR500 and HR500X units
- IPX5 rated



Heat Recovery Ventilation

HR500 heat recovery ventilation units for through the wall installation, which exhaust stale air whilst introducing warmed fresh air from the outside.

Ideal for computer rooms, classrooms, offices and the health and leisure industries. The Vent-Axia HR500 unit is the perfect solution for commercial areas that require a high performance balanced intake/extract ventilation scheme. As a heat recovery ventilation unit it moves a useful 153l/s of air.

The compact heat recovery cube interleaves outgoing warm air with incoming fresh air and allows the heat from one to warm the other without the two air streams mixing. Energy is saved on room heating with no power being used by the cube itself.

The HR500 and HR500X consist of a tough telescopic wall sleeve into which the main body of the unit is housed. Walls of up to 670mm thick can be easily accommodated. Behind the neat deflecting fascia grilles are the filters, the heat exchange cube and fan units. All wall sleeve components, the heat exchange cube and the fascia grilles are made of tough polymeric materials.

Electrical

Maximum ambient temperature +40°C.
Supply Voltage 220-240V/1/50Hz.

Models

HR500 Commercial

Wall-mounted intake/extract ventilation unit with built-in heat recovery facility. For commercial and leisure areas. Lightweight, compact and easy to install.

Model	Stock Ref
HR500	14101010B

HR500X

As HR500 with shutters.

Model	Stock Ref
HR500X	14101070

Controller

HR500 Controller

Surface mounting. On/Off remote sensor mode. Heat exchange, single fan extract or twin fan extract modes. Infinitely variable speed. Minimum speed setting. Suitable for controlling up to 2x HR500. 86 x 156 x 53 (W x H x D).

Model	Stock Ref
HR500 Controller	W14301010

Dimensions (mm)

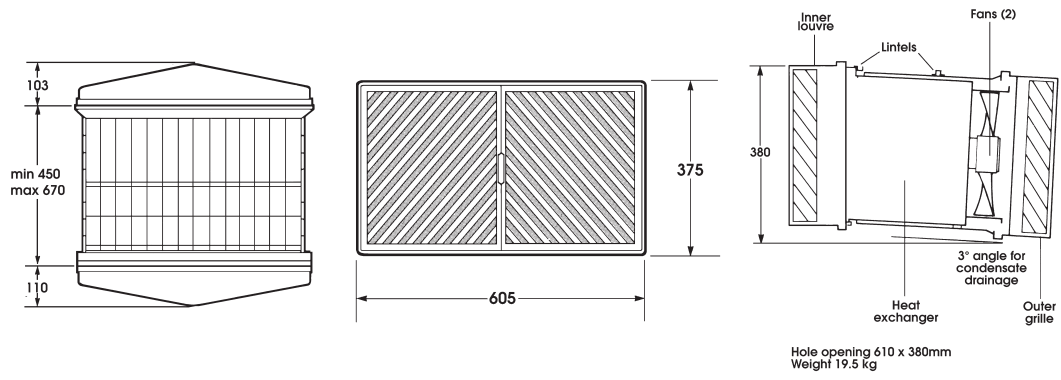

Performance

Model	Airflow performance (l/s)		Watts (max)	Sound dB(A) @ 3m (max)
	Heat recovery mode	Extract mode (max)		
HR500	153l/s	250l/s	200	53
HR500X	153l/s	250l/s	220	53