

F-2.3-07 (ISSUE 2) 06/11/2017

MANUFACTURING TABLE							
INITIAL 1	DATE	INITIAL 2	DATE	INSPECTION	INSPECTOR	INSP. DATE	SITE FITTING
				FULL / PARTIAL			YES / NO

ITEM NO.	PART NUMBER	DESCRIPTION	QTY.
1	920951-MD-02-001-A	Brush Base - Slotted	1
2	920951-MD-02-006-A	Bristle	27

NOTES:

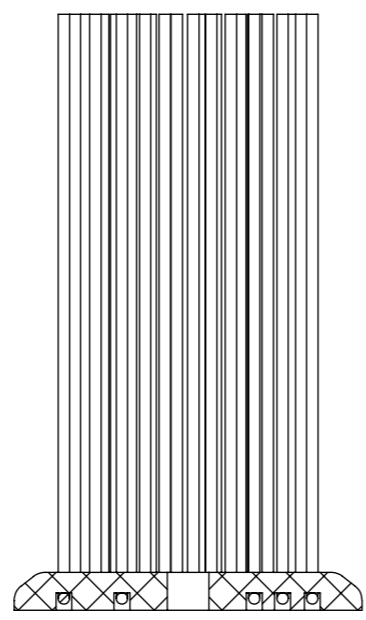
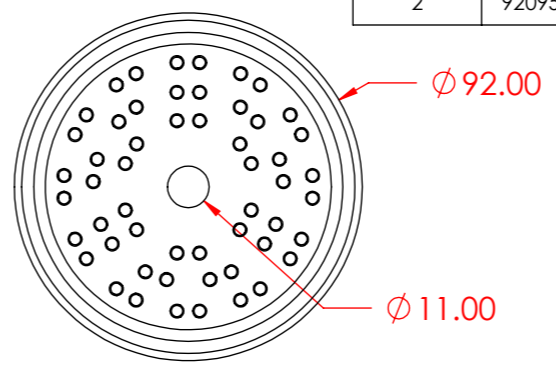
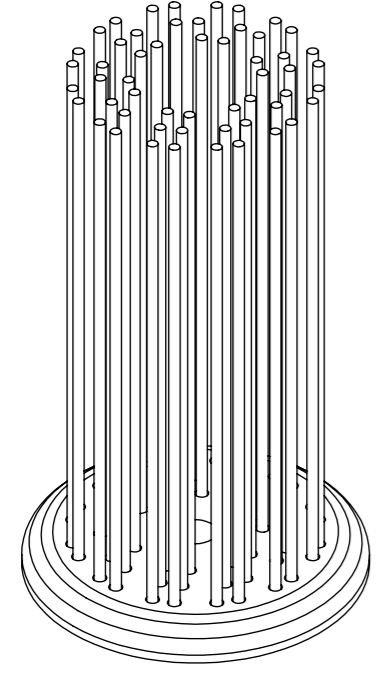

- REQUIRED CUSTOMER LENGTH _____. APPROVED_____.
- FIXINGS ARE DEPENDANT ON MATERIAL YOU ARE FIXING TO BUT ASSUMING A GOOD CONCRETE BASE IS PRESENT THEN:
M8 X 75mm GALVANIZED OR ST/ST SCREWBOLTS
M10 FORM A FIAT WASHER
****ALWAYS CHECK FIRST WITH INSTALLER ****

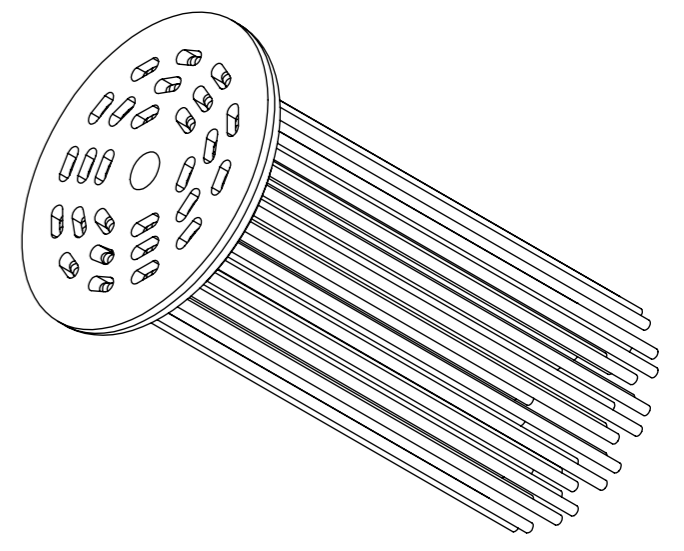
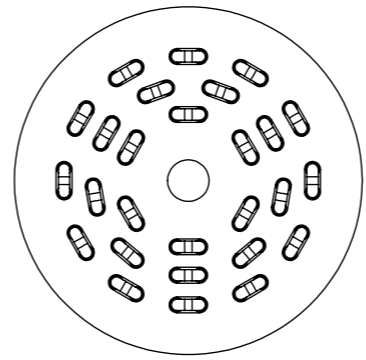
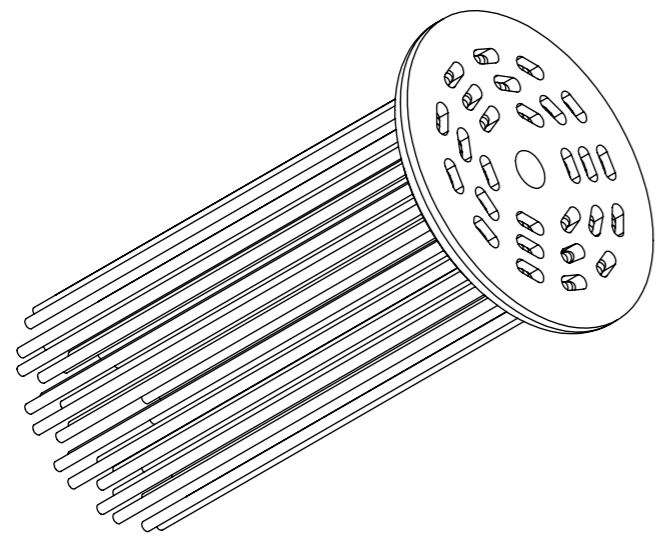
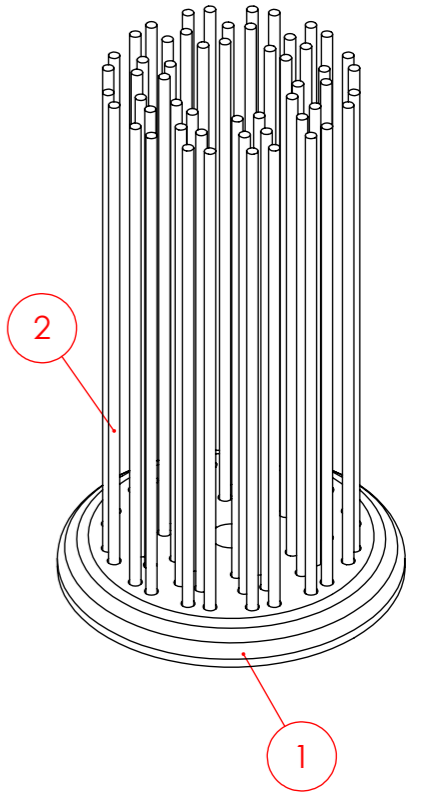
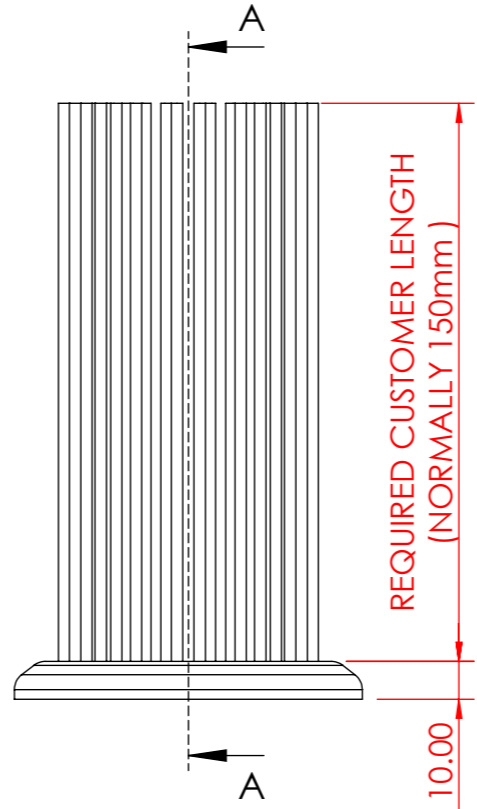

SECTION A-A



REVISION TABLE					
REV.	DESCRIPTION	DRAWN	APPROVED	JOB NUMBER (TICK IF SAME AS DWG NO.)	ISSUE DATE
A	First Issue	CJE	LB		25/03/19

 BERRY & ESCOTT ENGINEERING TEL. 01278 444861 WWW.BERRYESCOTT.CO.UK	UNLESS OTHERWISE STATED: ALL DIMENSIONS IN MM REMOVE BURRS & SHARP EDGES MACHINING TOLERANCES: X = ±0.5 X.X = ±0.25 X.XX = ±0.10 ANGLES = ±0.25° FABRICATION TOLERANCES: < 1mtr = ±0.5 1mtr > 2mtr = ±1 > 2mtr = ±2 ANGLES = ±0.5°	 THIRD ANGLE PROJECTION	DRAWING NAME: FISH BRUSH ASSEMBLY	
		DRAWING NO: 920951-MA-02-001-A		DRAWN:
THE INFORMATION CONTAINED IN THIS DRAWING IS THE SOLE PROPERTY OF BERRY & ESCOTT ENGINEERING Ltd. ANY REPRODUCTION IN PART OR AS A WHOLE WITHOUT THE WRITTEN PERMISSION OF BERRY & ESCOTT IS PROHIBITED.	MATERIAL: See Part Drawings	MASS: kg	DO NOT SCALE	
	FINISH: See Part Drawings	SCALE: 1:2	SIZE: A3	SHEET 1 of 1