

Notes
This drawing is to be read in conjunction with all relevant drawings and specifications.
Do not scale from this drawing. Use figured dimensions only. All levels and dimensions to be checked on site. All level and dimensional discrepancies are to be brought to the immediate attention of HSSP Architects Ltd.
Responsibility cannot be accepted for alteration and/or deviation from this design without prior acknowledgement of HSSP Architects Ltd.
Copyright reserved. This drawing may only be used for the client and location specified in the title block. It may not be copied or disclosed to any other third party without prior written consent from HSSP Architects Ltd.
Prior to any works commencing on site, the engineer is to be contacted regarding the current status, revision or regulatory approval of this drawing.
All work to be to the entire satisfaction of the NHBC or Local Authority not withstanding anything shown or indicated on these drawings. All workmanship and materials to be to the best of their respective kind and at least equivalent of the appropriate British Standard Code of Practice. All relevant dimensions and levels to be ascertained or checked and verified on site before specific areas of work are commenced.
This drawing is to be read in conjunction with clients specification/employers requirements and structural engineers design.

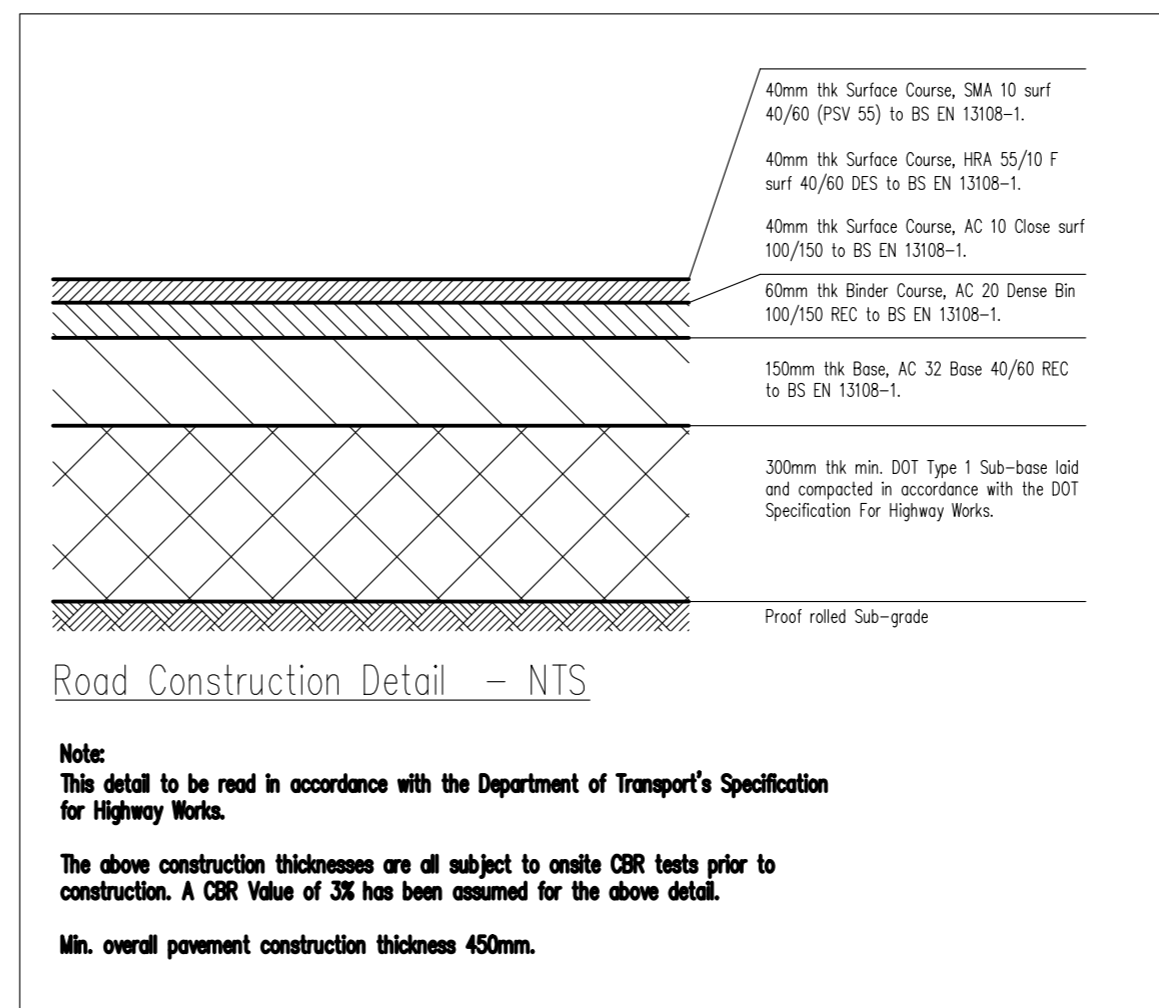
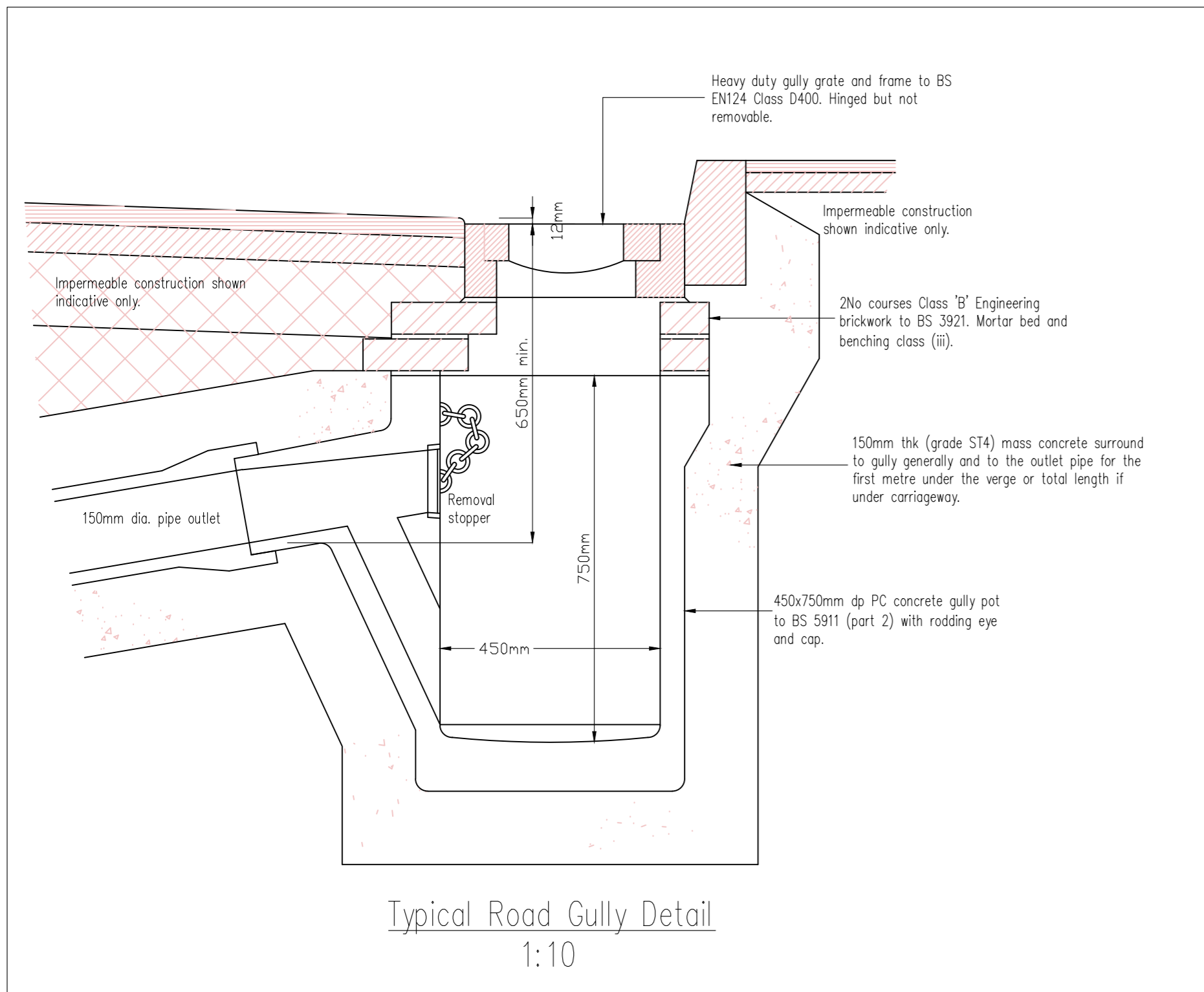
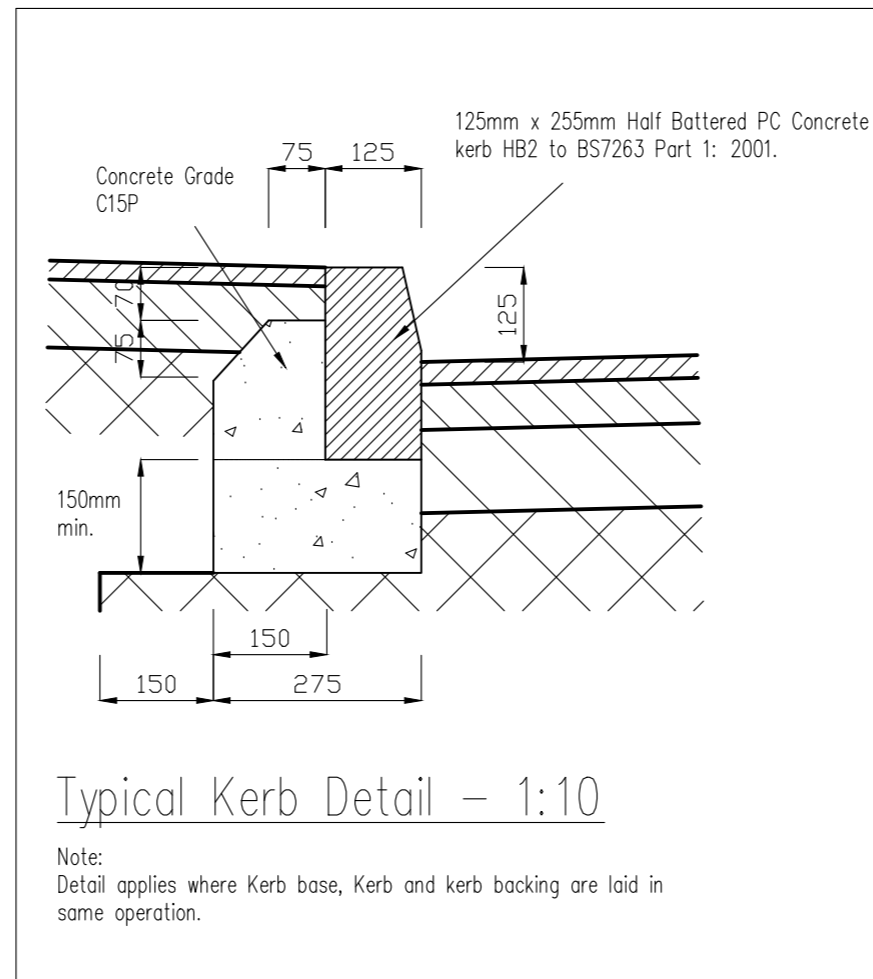
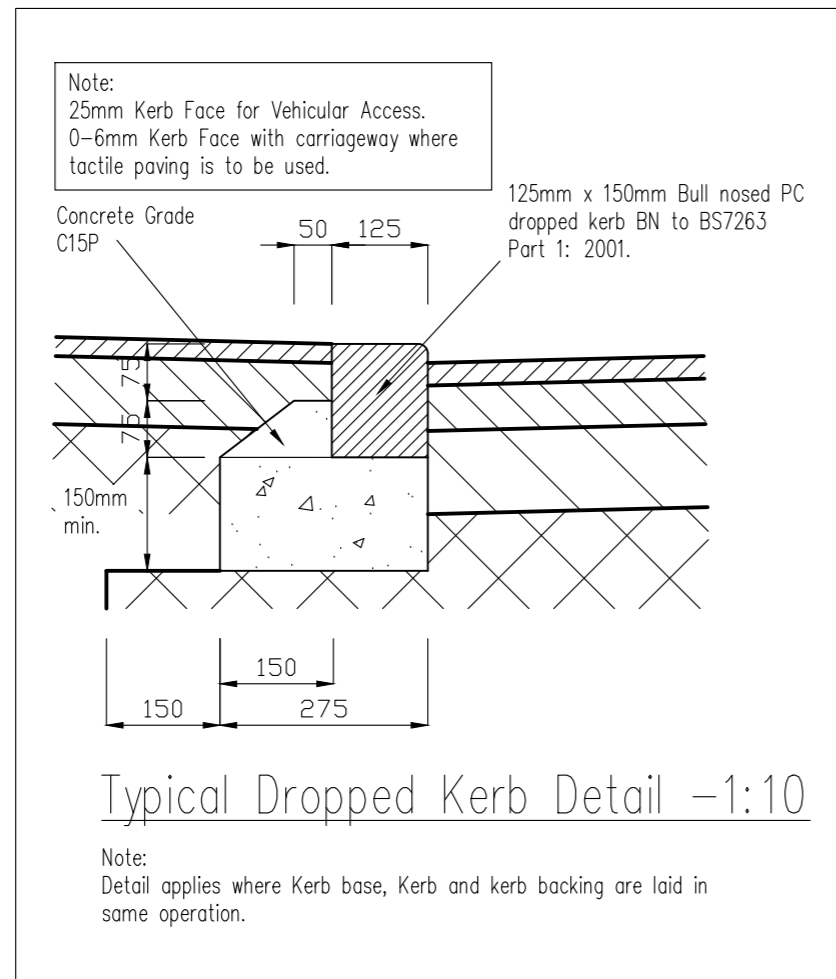
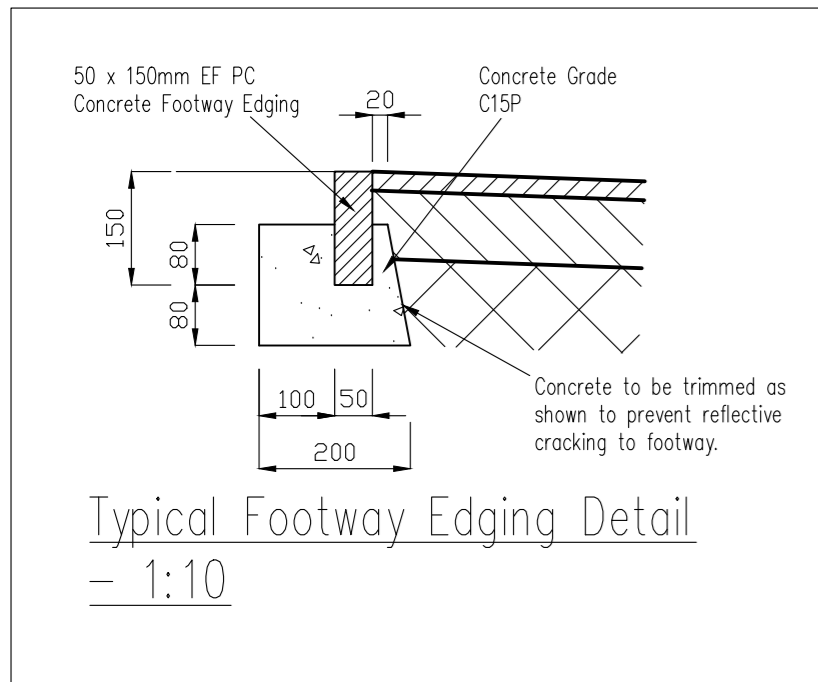

NOTE:
DRAWINGS TO BE READ IN CONJUNCTION WITH ALL HSSP DRAWINGS AND CONSULTANTS INFORMATION

T1 180518 SG Issued for Tender

Rev. Date Drawn



Pera Innovation Park, Nottingham Road
Melton Mowbray, LE13 0PB

Telephone: 01664 563 288 Fax: 01664 503 360
E-Mail: info@hssparchitects.co.uk Web: www.hssparchitects.co.uk

Project:
Proposed New Overflow Car Parking Area
Gynsill Lane Recreation Ground
Glenfield
For Glenfield Parish Council

Title:
TENDER - Typical Details

Scale: varies	Drawn: SG	Checked: NC	Date: February '18
Drawing No: 7600-05-003	Revision: T1		