



Science & Technology
Facilities Council



Design Guide for Mechanical, Electrical & Public Health Services – Rev 5



Amendment number	Description	Page/s	Date
Rev 1	Initial Draft Document		15/03/2018
Rev 2	Amended electrical section		25/07/2018
Rev 3	Additional information in Electrical Services section on substations		09/10/2018
Rev 4	Revised section B.1.1.2 Electrical design & Appendix C & D	31-33	21/01/2019
Rev 5	Modification to layout, contents etc. Amended Appendix E	All	22/08/2019



Contents

A.1	INTRODUCTION	1
A.1.1	Best Value	1
A.1.2	Objectives	2
A.1.3	Consultant Appointment.....	2
A.1.4	Responsibilities for design and information production	3
A.2	CONSULTATION AND ENGAGEMENT	3
A.2.1	Stakeholder Engagement.....	3
A.2.2	STFC Support structure	4
A.3	DESIGN STANDARDS	5
A.4	STAGE GATE APPROVALS.....	6
A.5	WORK ON EXISTING BUILDINGS	7
A.5.1	Fire Alarms and Detection System	8
A.5.2	Emergency Lighting Systems.....	8
A.5.3	STFC's Electricity monitoring Networked meters system.....	8
A.6	ENERGY CONSERVATION CONSIDERATIONS.....	9
A.6.1	Energy efficiency measures to be included in the Project.....	10
A.6.2	Environmental Issues.....	11
A.6.3	Passive Design Features	11
A.6.4	Building Fabric	12
A.7	PLANT LOCATION, ACCESS, OPERATION AND REPLACEMENT.....	13
A.8	METERING STRATEGY	15
A.9	COMMISSIONING AND TESTING.....	15
A.10	OPERATING AND MAINTENANCE MANUALS	18
A.10.1	General Requirements.....	19
A.10.2	Content and layout.....	20
A.10.3	Checking of Drafts.....	25
A.10.4	Final documentation.....	26
A.10.5	Copyright	26
A.11	RECORD DRAWINGS.....	26
A.12	BUILDING LOG BOOKS	28
A.13	HANDOVER.....	28
A.14	DEFECTS PERIODS NAMED MATERIALS/SPECIALISTS.....	29
A.15	WORKING WITH ASBESTOS.....	30
A.16	HEALTH AND SAFETY.....	30



ELECTRICAL SERVICES	31
B.1 ELECTRICAL GENERAL REQUIREMENTS.....	31
B.1.1 SUBSTATION DESIGN.....	31
B.1.1.1 General.....	31
B.1.1.2 Electrical Design	32
B.1.1.3 Building Design	34
B.2 LV ELECTRICAL SUPPLIES	35
B.3 ELECTRICITY GENERATING PLANT	36
B.4 POWER SYSTEMS	36
B.5 FIRE ALARMS, DETECTION AND SUPPRESSION SYSTEMS	37
B.6 LV SWITCHGEAR	38
B.7 RESIDUAL CURRENT DEVICES	40
B.8 DISTRIBUTION BOARDS.....	40
B.9 BUSBAR SYSTEMS	40
B.10 UNINTERRUPTABLE POWER SUPPLY UNITS	41
B.11 TRANSIENT SURGE SUPPRESSION, HARMONIC CONDITIONERS AND POWER FACTOR UNITS	41
B.12 ELECTRICITY METERING	41
B.13 EARTHING SYSTEMS	42
B.14 LIGHTNING PROTECTION SYSTEMS	42
B.15 POWER SERVICES	43
B.16 WIRING SYSTEMS.....	44
B.17 MONITORED DISABLED ALARMS AND SERVICES.....	44
B.18 INDUCTION LOOPS.....	45
B.19 LABELLING OF SERVICES.....	45
B.20 LIGHTING	46
B.20.1 LED Luminaires	46
B.20.2 Lighting Control Systems	47
B.20.3 Exterior Lighting	48
B.20.4 Specialist Lighting	48
B.20.5 Emergency Lighting	48
MECHANICAL SERVICES.....	51
C.1 MECHANICAL GENERAL REQUIREMENTS	51
C.2 UTILITIES AND INFRASTRUCTURE	51
C.3 PIPEWORK SYSTEMS.....	51
C.4 HEATING, BOILERS AND HUMIDIFICATION	52



C.5	HOT AND COLD WATER SERVICES	54
C.5.1	Hot water	54
C.5.2	Cold water services	55
C.5.3	Water Conservation	56
C.5.4	Above Ground Drainage	57
C.6	CHILLED WATER AND COOLING	58
C.6.1	Equipment Cooling.....	60
C.7	ISOLATION VALAVES.....	60
C.8	VENTILATION	61
C.8.1	Natural Ventilation.....	61
C.8.2	Mechanical Ventilation	61
C.9	COOLING TOWERS AND DRY COOLER	63
C.10	BUILDING ENERGY MANAGEMENT SYSTEM	64
C.11	CONTINUOUS AND OUT OF HOURS OPERATION.....	65
C.12	FUME CUPBOARDS	66
C.13	CONTAINMENT LEVEL 3 (CL3) LABORATORIES.....	66
C.14	PLANT MAINTENANCE.....	68
C.15	WATER HYGEINE RISK ASSESSMENTS/METHOD STATEMENTS	68
C.16	PLANT AND SERVICES ADJACENT TO PROJECT SITES	68
C.17	PRESSURE GAUGES AND THERMOMETERS.....	69
C.18	ELECTRICAL POWER SUPPLIES TO PUMPS	69
	APPENDIX A – BEMS SPECIFICATION.....	70
	APPENDIX B – STREET LIGHTING	74
	APPENDIX C – ELECTRICAL NOMENCLATURE (RAL) V2.....	79
	APPENDIX D – MANUFACTURERS/SUPPLIERS.....	90
	APPENDIX E – FIRE SAFETY REQUIREMENTS V.2	94

A.1 INTRODUCTION

These Engineering Services guidelines have been prepared to communicate STFC's MEP engineering services requirements. They are intended to guide and inform the Building Services Consultants, STFC Operations and Maintenance staff in the development and of engineering solutions for all STFC Capital/Strategic Maintenance Programme (SMP) projects for new build and refurbishment installations.

STFC will strive to ensure that the highest standard of engineering services installation and operations are achieved throughout the entire property portfolio.

The use of this design guide is not intended to take the place of, or remove any professional responsibility from the Consultants to fully comply with the requirements of a project brief. It would be impracticable to cover all eventualities given the diverse nature of STFC projects. Where deviation from these guidelines is considered appropriate, these should be subject to approval in writing by the STFC Estates Team.

The following sections give guidance on the required criteria for common installations. The Building Services Consultants are required to comply with the specific project requirements as laid down in the project brief or otherwise indicated in writing by the STFC Project Manager.

It is the intention of STFC to ensure that all works are provided to a uniform and high standard. This should be applied to the following;

- Compliance with the project brief, workmanship, quality and appearance
- Environmental control and energy consumption
- Reliability and quality of materials
- Maintainability and resilience of systems
- STFC Environmental Sustainability Strategy and Sustainable Buildings design specification

The technical standards and deliverables referred to within these guidelines are the responsibility of the Estates Team. They may not be varied without written approval of the STFC Estates Team.

These guidelines are a statement of the minimum standards of engineering services to be applied throughout the estate. They are not intended to stifle innovation and technical advances. STFC has adopted a long-term view with regard to longevity of equipment, cost effective energy saving measures and environmental issues.

A.1.1 Best Value

The Building Services Consultant should work both as a member of the team and individually in the spirit of trust, fairness and mutual co-operation for the benefit of the project to achieve transparent and co-operative exchange of information in order to obtain best value for STFC.

The Building Services Consultant should promote sustainable development objectives that deliver a high standard of design and installation, whilst meeting the economic needs of STFC. They should work in conjunction with the Sustainability Consultant to develop an environmental strategy, specific for each project.

The Building Services Consultant should assist in improving the image of STFC by raising standards within the STFC Built Environment whilst providing best value for money.

A.1.2 Objectives

This design guide has been compiled to achieve the following objectives:

- To provide guidance on design strategies in order to achieve, where reasonably practicable, standard engineering solutions whilst promoting energy efficiency and innovative designs.
- To harmonise building and site wide systems to facilitate cost effective and efficient operations, maintenance functions and standardisation.
- Historically there have been a diverse range of manufacturers' and specialist systems specified and installed across the STFC Estate over many years. This has made the Estates operation and maintenance functions difficult to manage resulting in high running and servicing costs. By standardising the building services engineering systems, the estate will be operated and maintained more efficiently /economically with reduced life cycle operation and maintenance costs.
- To standardise the use of building services engineering systems to facilitate best value solutions with manufacturers and specialists with respect to prolonged equipment and system warranties which will reduced life cycle operation and maintenance costs.
- To encourage the use of organisations with recognised energy, sustainability and environment certification and approval standards i.e. ISO 14001, Eurovent, Energy Technology List (ETA), etc.
- To promote a list of manufacturers and suppliers for use on STFC projects which can be located in [Appendix D – Preferred Manufacturers/Suppliers](#). If any of these are not feasible or there is a valid case for an alternative system/supplier that is not on this list then this should be formally agreed in writing with the STFC Estates Team.
- To facilitate and improve site records and site engineering data by utilising and updating live data systems currently being implemented across the STFC Estate.
- To maintain and keep updated STFC site wide master and live utility services records - i.e. BEMS topography, steam and condensate, water, gas, LV and HV distribution and communications, etc.
- To maintain updated individual STFC building master and live schematic records - LTHW, CHW, domestic services, small power, lighting, fire alarms and security etc.
- To provide the Building Services Consultants with live data of the existing site, building infrastructure and utilities which will assist in design development during each project stage. This will facilitate a building services engineering management tool which will become a live interface for co-ordination between various projects which may be at different stages of design and construction phase undertaken by different parties.

A.1.3 Consultant Appointment

All Consultants should carry out their duties in accordance with the STFC Framework Agreement based on General Conditions for the Appointment of Consultants Framework Agreement.

The Consultant's duties should be based on the following appointments:

- Duties of the Building Services Engineer - multidiscipline projects

- Duties of the Building Services Engineer (Design and Build)
- Duties of the Lead Consultant - e.g. predominantly engineering based projects.

Note: Each annex outlines the plan of work and organises the process of managing and designing projects into a number of key work stages. The sequence or content of work stages may vary or they may overlap to suit the procurement method, and should be finalised with STFC Project Manager.

Where no formal environmental/energy advisor(s) have been appointed, the Building Services Consultant may be asked to act as the environmental lead or champion as an additional service.

All Building Services Consultants will require a valid CSCS card to the appropriate level when visiting any STFC site during either construction or carrying out survey works.

A.1.4 Responsibilities for design and information production

The Building Services Consultant should take responsibility for the complete design of the works including developing the conceptual design into a fully coordinated detailed design.

Throughout the design stages they will be actively involved with the STFC design/project team, operational and maintenance team and be responsible for undertaking and preparing any such design sketches, details or information required by other design team members to enable their element of the work to be detailed.

During the design and information production stages the STFC Project Manager and STFC Estates Team will monitor the development of the design and the production of the detailed and coordinated design.

A.2 CONSULTATION AND ENGAGEMENT

A.2.1 Stakeholder Engagement

During the project briefing, design development, installation, commissioning and handover, engagement by the Building Services Engineer with key stakeholders will be paramount. It will be the responsibility of the Building Services Engineer in conjunction with the STFC Project Manager to communicate and engage with these stakeholders at each appropriate stage of the project.

Discuss outline scheme with:

- Local Planning Authority (if necessary)
- STFC Head of Safety (laboratory design, radiation and biological hazards, health and safety at work, etc.)
- STFC Fire Officer
- Oxfordshire Fire Brigade
- STFC Estates Team

- STFC Facilities Management
- STFC Energy Manager
- STFC Audio Visual Teams
- STFC IT Manager (DS)
- STFC Telecommunications Manager
- STFC Security Manager (Security and Parking) and Access Systems
- STFC End User Representatives

A.2.2 STFC Support structure

STFC Estates, along with other service providers, provide support and advice on STFC's requirements for both property design, operational, maintenance and safety matters.

Liaising with all the necessary parties at STFC can often be one of the most challenging aspects of the design and briefing process but it is a very important requirement.

STFC Estates consists of the Capital Projects, Estates, Operation and Maintenance, Health and Safety and Sustainability teams who are responsible for the following STFC sites across the Estate:

- RAL Laboratories (Offices, Test Facilities, Catering etc.)
- Chilbolton
- ATC Edinburgh
- Daresbury
- The Coseners House (Residential)
- Ridgeway House (Residential)

The key STFC personnel/teams represented are as follows:

CONTACT DIRECTORY

Rutherford (RAL)

Title	Email	Telephone
Head of Estates and Facilities Management	liz.kitchener@stfc.ac.uk	01235 446633
Head of Estates and Facilities (RAL)	Adam.bamford@STFC.ac.uk	01235 445105
Estates (Head of Engineering)	David.matthewson@STFC.ac.uk	01235 446210



Estates (Mechanical)	Kay.belcher@STFC.ac.uk	01235 445161
Estates (Electrical)	Alastair.sharp@STFC.ac.uk	01235 446823
Estates (Operations)	Giles.digby@STFC.ac.uk	01235 446205
Energy Manager	Craig.brown@STFC.ac.uk	01235 446506
Head of SHE	Graeme.finlan@STFC.ac.uk	01925 603147
Security Manager	David.hackett@STFC.ac.uk	01235 446370
Fire safety adviser	Stephen.wollen@STFC.ac.uk	01235 445476

It should be noted that discussions and agreement with any of the above parties do not in themselves form an official contract instruction and the Building Services Consultant is required to outline any proposals intended to be taken on board to the STFC Project Manager and STFC Estates team to obtain their formal approval.

When liaising with contacts on this list the Building Services Consultant should at all times copy notes and correspondence to the STFC Project Manager to ensure that they are aware of all matters relating to the project.

A.3 DESIGN STANDARDS

STFC requires that all engineering services installations are completed in full compliance of all statutory requirements and industry best practice guidelines. In addition, all standards, Codes of Practice, design guides and guidance notes issued by various bodies such as the British Standards Institution, Chartered Institute of Building Services Engineers, Health and Safety Executive etc. should be complied with. These may include but not limited to:

- CIBSE Guides and Technical Publications
- Current British and European Standards
- Current Legislation and Statutory Obligations
- Local Authority Regulations
- Home Office Guidelines
- BS 7671, IEE Wiring Regulations, 18th Edition
- Building Regulations
- British Standards/ EN ISO
- Health and Safety Executive guidance documentation
- Gas Safety (Management) Regulations, 1996
- Gas Safety (Installation and use) Regulations 1998 (Amended 2001)



- Water regulations
- CDM and Design for Safety Regulations
- Insurance Company
- Planning Authorities
- Building Control Officer
- Environmental Health Officer
- Fire Officer
- The STFC fire safety policies [SHE codes](#)
- Where appropriate BREEAM, Ska or equivalent.

It is the Building Services Consultants responsibility to ensure that all relevant standards are current at the time of design, installation and completion.

As part of its Health and Safety regime; Estates have produced specific procedures and Permit to Work systems. These are listed below for information:

- [Asbestos SHE codes](#)
- Roof Access - Permit to Work
- Confined Spaces - Permit to Work
- HV Electrical - Permit to Work
- Hot Works – Permit to Work
- Hazardous Area - Permit to Work
- Excavation – Permit to Work

A.4 STAGE GATE APPROVALS

The design deliverables and proposals identified at each stage gate will require the full approval and/or agreement of STFC and their designated representatives prior to commencing to the next stage of the project.

Design reports, construction specifications, drawing comments and approvals should be provided to ensure site works are not delayed; however it is the responsibility of the Building Services Consultant and/or Contractor to achieve the programme requirements.

The MEP Stage Gate deliverables/roles & responsibilities will be submitted at the beginning of the project to identify the key submissions and documentation required at each stage of the life cycle process. Each report, specification or set of drawings should be submitted to suit the individual programme of each project, however a minimum of 2 weeks will be required by STFC to review each document and provide feedback.

A workshop with all appropriate stakeholders should be arranged to include a presentation of the entire scheme at stages C and D of design. The entire project team should be available but the workshop will be facilitated by the Building Services Consultant and STFC Project Manager.

The review of all reports and drawings will follow an A, B, C commenting/approval process as outlined below:

- A. Designating drawing has no comments proceed
- B. Drawing has minor comments, integrate the comments and proceed
- C. Drawing to be re-submitted integrating comments

It will only be possible to proceed to the next design stage with a 'B' status with comments but only at the discretion of the STFC Estates team and the STFC Project Manager.

A.5 WORK ON EXISTING BUILDINGS

When starting a refurbishment or fit-out project the Building Services Consultant should obtain all current and existing building and system information. As a minimum STFC will provide O&M's, record drawings, system schematics, asbestos records and water treatment, testing and regime records where available.

Additional information should be obtained from the following sources:

- STFC Project Manager
- STFC Estates Team
- STFC FM Team
- STFC Safety

Should any relevant information not be available the Building Services Consultant should undertake a detailed survey of the building and associated systems to produce system schematics of all Building Services systems associated with the entire building for which the works are proposed.

This exercise should be undertaken in conjunction with the STFC Estates team and may require independent specialist contractors to be employed particularly where tracing and testing of services and when intrusive surveys are required.

All surveys will require the standard STFC Data Collection sheet to be completed and submitted to the Estates team. All schematics and documentation produced should make reference to the individual plant and equipment STFC Asset Management System references.

All plant and equipment being de-commissioned as part of the proposed works shall be removed as part of

the contract. This should include but not be limited to the following associated components:

- Plant and equipment
- Connecting ductwork, pipework and all associated ancillaries and supports.
- Power, wiring, controls and associated ancillaries and supports.
- Meters

All relevant information to be provided for the update of the STFC Asset Management system and a revised set of drawings should be produced as part of the works.

A.5.1 Fire Alarms and Detection System

These should be decommissioned by STFC's termed Maintenance contractor for the Fire Alarms systems. As outlined in STFC's Fire Safety Technical Guides, decommissioning should involve the conversion of the system to construction site requirements by replacing smoke detectors with heat detectors in the identified area/s. The Building Services Consultant should be liaising with STFC's Fire Officer in regards to the decommissioning works.

The replacement of smoke detector with heat detectors is only considered part of the requirement necessary for mitigating the possibilities of false alarms due to construction site pollutants whilst providing some fire coverage to the site area. Methods of restricting such pollutants from circulating to other parts of a building still in occupation should be addressed at design stage.

If smoke detectors are to be retained then these should be isolated during the working day and activated during periods of non-occupancy. This can be arranged through the Estates team.

A.5.2 Emergency Lighting Systems

Where existing central battery systems exist, critical elements such as the cabling and battery system should not be decommissioned in an occupied building until replacement systems or alternative connection measures are in place.

For self-contained emergency luminaires with traditional local controlled test key switches no special allowance for decommissioning required.

For self-contained emergency luminaires complete with addressable testing modules and connected to a central addressable emergency panel, decommissioning should be carried out by the manufacturer or any termed contractor managing the system.

The Building Services Consultant should familiarise themselves with existing systems and incorporate clause(s) within the specification for the decommissioning works ensuring this does not compromise coverage for the occupied areas outside of the contract site.

A.5.3 STFC's Electricity monitoring Networked meters system

As a dual function of meeting Building Regulation part L and enabling better power/energy management at STFC, intelligent electricity meters are installed linked back to a head-end PC in the Estates, Electrical Services offices via a VLAN data network.

Decommissioning of any part of this network should be discussed and agreed with STFC's Building Services Team at design stage.

NO PART OF THIS SYSTEM SHOULD BE DISCONNECTED, ALTERED, ADAPTED OR REMOVED WITHOUT WRITTEN APPROVAL FROM THE ESTATES TEAM.

The Building Services Consultant should allow to completely strip out and remove from site all redundant equipment and wiring, or where this is not possible a clearly defined description of the extent of removal will be required. The Building Services Consultant will also be responsible for verifying this has been carried out by the contractor in a safe manner, and to STFC's satisfaction.

A.6 ENERGY CONSERVATION CONSIDERATIONS

The following energy conservation guidelines are not intended to be a design manual, but to provide guidance to Building Services Consultants on STFC's requirements for the procurement of new buildings or the refurbishment of existing buildings. STFC are keen to identify and act upon the opportunities offered by all projects to improve the energy efficiency of the estate.

STFC emphasise that the requirements of this document are not meant to restrict designers, but rather to prompt them to be innovative, and to go beyond the minimum requirements of building regulations. The initial cost of buildings is less important to STFC than their cost in use and their overall environmental impact.

The onus is upon the Building Services Consultant to ensure that all measures in this guide are considered and ensure that a record is made of whether a measure is to be included or excluded, the budget that will finance each measure; and, where applicable, the reasons for excluding measures.

The Building Services Consultant should work in conjunction with the Sustainability Consultant and other team members in assessing the viability of all energy efficiency measures.

For all projects a Carbon Appraisal should be undertaken between design Stages 1 to 2 (GC Works Stage 1) for all plant and equipment whether it is to be retained or replaced as part of the proposed works. This appraisal should align with the STFC Carbon Appraisal Methodology and should broadly consist of the following:

- Energy consumption in use
- Energy efficiency in use
- Carbon emissions in use
- Life cycle analysis
- Reliability
- Maintenance costs
- Controls

- Cost of carbon abatement

This appraisal should be undertaken and the resulting recommendations commented and approved by the STFC Project Manager, Estates Sustainability team prior to the project being presented to the Estates.

All energy and water consuming plant, equipment and products should be selected in conjunction with the STFC Estates and Sustainability teams and in line with the approved technology lists and BRE Green Guide.

A.6.1 Energy efficiency measures to be included in the Project

All energy efficiency measures included in this guide should be considered for inclusion in the refurbishment of areas as well as new projects.

Measures that are compulsory under the current revision of the Building Regulations or other legislative requirement must be included in the project.

Energy efficiency measures that are directly related to the Project Brief will be implemented.

Criteria for the return of investment in energy efficiency measures that are not directly related to the Project Brief are as follows:

- Energy saving measures should be considered cost effective providing that a simple payback period of seven years may be achieved. This payback should be calculated using the STFC Energy Payback Review.
- The designer will identify all energy efficient measures applicable to the refurbishment programme.

Legitimate reasons for excluding a measure will include the following:

- Not applicable to the works being carried out.
- Measure non-compulsory and payback period would be greater than 7 years.
- Approval to exclude the measure has been given in writing by the STFC Estates team. Discussions with the STFC Sustainability team may also be required.

Variation from this guide must be approved by the STFC Estates team or key project stakeholders.

Key elements for consideration on any new STFC buildings or on refurbishment should include, but should not be limited to the following;

- Solar PV Panels on suitable roof spaces – time for planning permission etc. should be accounted for in project.
- Inclusion of some form of battery/energy storage.
- If stand-by generation is a part of the original project brief, consideration should be given to the size of generation asset – if over 250kW these assets may be used for Demand Side Response activities and thus will require the appropriate G59 connection agreement and associated works. This should be



factored in to any payback calculations.

- Voltage Optimization Units – depending on the planned fit out of the building/area this technology should be considered.
- Full LED lighting systems, designed with appropriate LUX levels. Any lighting will be installed with PIR sensors and daylight/LUX sensors.
- Sub – metering and connection in to the existing STFC sub – metering network. Complete minimum inclusion would be consumption of electricity, gas and water – additional sub metering should be discussed at a project level.
- Quick dry hand driers (Airblade or similar) should be included in all bathrooms.
- All water outlets should be fitted with aeration devices.

Where there is any contradiction between this document and any other contract documents, this will be brought to the attention of the STFC Project Manager and Estates team.

The STFC Project Manager and Estates Team will be consulted with regard to interpretation of this energy conservation guidance or other documents it refers to. This will apply in particular when there is a need to make a professional judgement on what is acceptable and/or affordable.

A.6.2 Environmental Issues

STFC is conscious of its environment responsibilities in the procurement of its new buildings and refurbishment projects.

The Project should:

- Select local suppliers where available.
- Consider the energy used in the manufacture and supply of plant and equipment, and where possible use materials with low energy input.
- Choose suppliers who have a clearly stated policy of minimising the environmental impacts of their products.
- Evaluate the environmental performance of tenderers, when relevant to the contract.
- Use the EU energy and water consumption-rating scheme to choose more efficient goods when fitting out new building. Consideration should be given to the energy and water technology lists.
- Consider the use of renewable energy sources such as onsite photovoltaic cells.

A.6.3 Passive Design Features

The layout and orientation of new buildings should be planned to maximise winter solar gains and natural day lighting and reduce summer overheating. These passive measures will be in place for the life of the building and will require minimal maintenance compared to active systems. The successful integration of

passive features into building design demands early interaction between the architect, the Building Services Consultant, planners and the structural engineer.

For a given internal floor area, external wall areas can be minimised through the use of compact building forms.

Passive solar atria can be used to enhance both day lighting and natural ventilation. They require careful design, orientation and management: if poorly designed they can lose more energy than they gain.

The optimum method of testing the comparative thermal performance of alternative designs is to use a dynamic thermal simulation program. A suitable program should be used to optimise the design of a new building. Where extensive use is to be made of natural ventilation, computational fluid dynamic (CFD) simulation may be used to test its effectiveness.

The Design Team should:

- Use compact building forms optimised to maximise day lighting, maximise winter solar gain and minimise winter heat loss.
- Use internal thermal mass to absorb heat on hot summer days, and vent unwanted heat to the atmosphere overnight through natural ventilation.
- Consider the use of passive solar atria.
- Consider the use of light-shelves to increase penetration of daylight into buildings.
- Consider the use of planted shelter belts to reduce wind speeds around buildings.
- Consider the use of dynamic thermal simulation programs, and computational fluid dynamic (CFD) simulations to validate designs.

A.6.4 Building Fabric

Where internal finishes of external walls are being altered, insulation should be considered current to ensure that the external walls comply with the minimum 'U' value under the current Building Regulations, Approved Document Part L2B.

The design team should take account of exemptions to this and other building regulations requirements arising from the conservation or heritage status of a building.

Where extensive window replacements or other changes to external building fabric are being undertaken, reference should be made to the use of external shading and the minimisation of solar gain. The consideration of secondary glazing systems may be appropriate where glass replacement may not be either practical or economically viable.

Where solar gain will cause glare or lead to excessive internal space temperatures, options for internal blinds, glass replacement or retrofit window films should be considered.

The position of all heating and ventilation sensors will be marked on a plan of the building by the designer, prior to the design stage for the refurbishment of existing internal walls, or the installation of new ones.

The location of new internal walls will be designed to avoid impairing the function of existing heating and ventilation systems and their control.

Where heating and ventilation systems or their control equipment are disturbed by the location of new walls reference should be made to the heating, ventilation and control sections of this energy conservation guidelines.

Where existing suspended ceilings are being replaced, modified or new ones installed, the STFC Project Manager should be informed and consideration should be given to taking the opportunity to install lighting and HVAC control and communications cable or other energy saving systems that may need to be accommodated above the suspended ceiling.

Some of STFC's properties are either listed or have been assigned another form of protection in planning law by the local authority. These and other planning requirements should be firmly adhered to in all refurbishment and new build projects.

Building Regulations specify the minimum insulation levels for new buildings. This should be the starting point when reviewing the upgrade or replacement of building fabric elements.

The design team should look to improve on these values wherever possible. In practice a super-insulated building should be combined with optimisation of the total energy performance of the building, including maximum use of daylight and winter solar gains, together with shading to minimise summer overheating.

The design team should:

- View the requirements of the Building Regulations as a minimum standard only.
- Optimise the total energy performance of the building, to make maximum use of daylight and winter solar gains, and minimise summer overheating.

A.7 PLANT LOCATION, ACCESS, OPERATION AND REPLACEMENT

Mechanical and electrical plantrooms should be separate rooms and both must have safe, easy secure access and be of adequate size and height. Ventilation, sealed floors, painted walls (in electrical plantrooms), floor drainage, good uniform lighting, emergency lighting, fire sounder and appropriate detection as a minimum should be provided to the room where applicable. If the building has a goods lift then this should be at the same level and as close to the plantroom as possible.

Door locks to the plantrooms shall be Euro cylinders and follow the master key series which shall be obtained from Estates. All substations are to be fitted with door holders not closers so that they can be latched open.

Electrical areas should not be open to the elements (unless specifically designed as an outdoor substation) so should have solid walls and doors with adequate heating to prevent any moisture condensing in or around equipment and maintaining the humidity below 70%. Humidity sensors should be installed and connected to the BEMS in areas containing HV equipment. Transformer rooms; where cast resin transformers are used the room should be sealed as above but with temperature controlled extract fans with small louvers in the doors; where oil filled Transformers are used, such rooms may be louvered, but the preference would be for construction to be as above but with temperature controlled fans.

Ensure all drainage in the plantroom falls towards the drainage points and where sensitive areas are below

'wet' areas then consideration should be made to tanking and bunding of the area. All fluid filled transformers shall be in a bunded area which is capable of holding the full quantity of fluid. Where these are sited externally the transformer shall be covered by a high level canopy.

Discharges to plantroom drains e.g. from condense, blowdown shall be adequately designed and installed to prevent water leaking onto the floor. If there is a need to bund then a separate drain should be considered to cope with the flow.

Adequate space shall be provided around all plant for safe maintenance, inspection and replacement. Headroom under plant, pipes, ducting etc. along access routes shall not be less than 2000mm with access around plant being not less than 900mm or more if required by the manufacturer. A minimum clearance of 450mm to be maintained below any item of plant, pipework or ductwork running on or across roof finishes. This is to enable roof maintenance to be carried out without the need to remove or raise services. This does not apply to plant mounted on concrete bases.

The plant shall be installed as to prevent vibration and noise transmission to occupied areas and surroundings. Appropriately positioned lifting beams shall be provided to enable the safe replacement of larger items of equipment such as pump motors. Where a lifting beam is not possible then method statements and risk assessments must be submitted before installation for approval by STFC Estates.

All plant and equipment should be located wherever possible outside of occupied areas. This is particularly important for laboratory areas where fixed furniture and equipment may impede on safe access for maintenance.

The design of all systems must demonstrate that all plant and equipment incorporated into the works can be safely and easily maintained in full compliance with Health and Safety legislation, CDM requirements, British Standards etc.

Ensure that all access panels/doors are unobstructed and that adequate space is provided for future replacement of plant or parts.

All walkways and stairways should be designed in accordance with all relevant and current British Standards and safety codes and guidance and should include all toe plates, railings, guards and in fills necessary to ensure a safe installation.

External installations should be finished with a polyester powder coating in a BS or RAL colour advised by the Architect.

Where services are boxed in or concealed within the building fabric or building finishes such as floors and ceilings, safe and suitable access should be provided so that they can be accessed by a single person without tools and identification of the concealed services provided post completion of works.

The Building Services consultant should produce at Stage 4 a detailed Plant Replacement Strategy. This independent document should be presented to the STFC Estates team for comment and approval prior to the commencement of detailed design. The report format should be flexible but cover through descriptive text and supporting sketches the provision for safe and practical plant installation, maintenance and replacement. The document should not only consider the existing and proposed works but any future master plan works associated with adjacent and surrounding buildings or public realm areas.

Once approved the Building Services Consultant must maintain this document throughout detailed design and ensure that it is adopted by the contractor during the works and presented within the final O&M's.

The Building Services Consultant should work with the support of the STFC Estates team to ensure that these measures are incorporated.

A.8 METERING STRATEGY

At Stage 4 the Building Services Consultant should produce an Energy Metering Strategy that should meet the requirements of the Building Regulations and CIBSE TM39.

This document should be presented to the STFC Estates and Sustainability teams for comment and approval prior to proceeding to detailed design. It should remain the responsibility of the Building Services Consultant to maintain this document through detailed design to handover.

Under a Design and Build contract the contractor should become responsible for this strategy with the Building Services Consultant responsible for the review and approval of the strategy at production information and construction stage.

All sub metering should be agreed with the STFC Estates and Sustainability teams with all meters to be STFC Energy Monitoring System/network compatible for central energy monitoring purposes. This should be through RDM (Resource Data Management) and KWHEB systems.

A.9 COMMISSIONING AND TESTING

For all projects an independent Commissioning Manager should be appointed. The role of the independent Commissioning Manager is to ensure that all systems and components of a building or industrial plant are designed, installed, tested, operated, and maintained according to the operational requirements of the owner or final client. Therefore, a Commissioning Manager should be appointed during the design stage of a project. An independent Commissioning Manager should be appointed to meet the requirements of BREEAM or Ska.

The role is to ensure that commissioning is carried out in line with current building regulations, BSRIA and CIBSE guidelines. The following lists the responsibilities of the specialist commissioning manager;

- Design input - reviews of the project, its design and commissionability. A detailed examination of the design specification and drawings, supplemented by site inspections would be undertaken. Confirmation/recommendations would be provided concerning the capability of the system in a safe and proper manner
- Programming - to review and contribute management input into the construction programme. Working with the contractors' commissioning team to ensure practical solutions were achieved in the shortest time possible and monitoring changes to the design scheme to ensure effective commissioning facilities are provided at all times
- Installation stage - to review and advise during this stage to ensure the proper development of the commissioning process. Undertake initial tests and pre-commissioning as systems are complete. Ensuring systems are protected to avoid damage during commissioning and early installation stages
- Management - at the following stages of commissioning, performance, testing and handover/post-handover. Ensuring the proper provision of contractors' method statements, test and commissioning certificates and O&M's

On completion of the project, and to gain additional accreditation, the commissioning manager will be responsible for the seasonal commissioning over a minimum 12 month period once the building is occupied. Testing of all the services under full load conditions and under part load conditions may be undertaken (i.e.

throughout the 4 seasons). Interviews with building occupants may be undertaken to identify problems or concerns regarding the effectiveness of the system. Re-commissioning of systems may be undertaken as identified to serve revised loads.

All commissioning and testing should be undertaken in line with Part L, CIBSE and BSRIA Soft landings. Where used in this guide, the following definitions apply:

- Commissioning - the advancement of an installation from the stage of static completion to working order and to the specified requirements.
- Testing - the measurement and recording of specified quantifiable characteristics of an installation or parts thereof. This includes off site testing.
- Setting to work - the process of setting a static system in motion.
- Regulation - the process of adjusting the rates of fluid flow in a distribution system to achieve specified values.
- Environmental testing - the measurement and recording of internal temperatures during commissioning.
- System proving - the measuring, recording, evaluating and reporting on the seasonal performance of the systems against their design values.
- System demonstration - demonstrating the capability of the installation to achieve and maintain the specified performance criteria.
- Fine-tuning - the adjustment of the system where usage and system proving has shown such a need. This may include the re-assessment of design values and control set points to achieve the required system performance.

When compiling the contract documentation, the Building Services Consultant should ensure that the following is communicated and policed throughout the installation stage of the project:

- Notify the STFC project manager/commissioning representative in writing when the works or parts thereof are ready for testing and commissioning.
- Provide all necessary facilities to enable tests to be witnessed and inspections carried out including all necessary instruments and recorders to monitor systems during commissioning system proving and environmental testing.
- Prepare comprehensive programmes, commissioning plans, schedules and method statements and procedures supported by risk assessments for the pre-commissioning checks, setting to work, commissioning, system proving and environmental testing of the Works.
- Monitor progress against the program of works and provide weekly reports detailing progress of testing and commissioning activities.
- Appoint a "competent person" to supervise the whole of the testing, commissioning, system proving, system demonstration and instruction of the employer's staff.



- Co-ordinate the activities of all specialised personnel, including manufacturer's representatives, together with providing any attendance required.
- Indicate on drawings where access is required into ceiling voids, service risers etc. and ensure these points are not closed up until the commissioning and testing is complete.
- The Building Services Consultant and/or STFC representative should be given the opportunity to examine, subsequent to setting to work and regulation of the works the results of the commissioning and the documentary records thereof.
- Ensure all requirements such as cleanliness, protection from harmful external and internal elements are provided prior to commencement of commissioning.
- Comply with the requirements of the Building Regulations (Approved Document Part L2) for the inspection and commissioning of the building services systems. Prepare all necessary submittals including commissioning plans and reports. Obtain all compliance approvals from the building control bodies.

The object of the witnessing stage is to enable the Building Services Consultant and/or STFC representative to establish a level of confidence in the commissioning results being presented. The extent and proportion of results to be witnessed by the Building Services Consultant and/or STFC representative should be at the discretion of Building Services Consultant and STFC.

The Building Services Consultant and/or STFC representative should only witness test the completed systems preceding the receipt of recorded results from the commissioning and should determine if the specified requirements have been satisfied.

Should the tests fail to demonstrate that the plant and equipment are properly designed, installed and functioning correctly, the cause of the failure should be investigated. Should the failure be due to incorrect design or faulty work then without delay, carry out such remedial measures and adjustments as may be necessary and repeat the commissioning and testing procedure to the satisfaction of the Building Services Consultant and/or STFC representative.

Where it is not possible at the particular time of commissioning and testing for full load conditions to be obtained or simulated, then as soon as this can be achieved then this should be offered to the Building Services Consultant and/or STFC representative.

The works should be fully tested, commissioned and be fully operational prior to witnessing and inspection by the Building Services Consultant and/or STFC representative

Where portions of the works are required to be commissioned and tested separately, then upon final completion, the Contractor should demonstrate to the Building Services Consultant and STFC representative that all of the portions are capable of proper simultaneous operation in accordance with the requirements of the specification.

In cases where the construction programme is such that the commissioning, testing, balancing and adjustment needs to be undertaken in an area of the building taken over and occupied by STFC, the Contractor should take all necessary precautions against and be responsible for any damage and remedial works that may occur.

Submit to the Building Services Consultant and/or STFC representative written reports signed by a

"competent person" to confirm that:

- Prior installation - all system designs can be commissioned.
- Post installation - installations complete and ready for commissioning.
- System cleanliness - specified cleanliness has been achieved.
- Pre-commissioning checks - completion of pre-commissioning checks
- Commissioning and testing - demonstrate compliance with specified requirements and confirm that each installation has been correctly tested and commissioned and achieving the specified performance.

A.10 OPERATING AND MAINTENANCE MANUALS

The Contractor should employ a STFC Estates approved independent company who specialises in the preparation of operation and maintenance manuals to provide the manuals in accordance with the requirements of this guidance document.

Four weeks before the contracts practical completion date, a draft copy of the operating and maintenance manual(s) should be issued to the Building Services Consultant and Estates team for comment.

PRACTICAL COMPLETION SHALL NOT BE OBTAINED UNTIL THIS INFORMATION IS COMPLETE AND APPROVED BY STFC.

The final O&M's should include a full schedule of plant and equipment referenced in line with the STFC Asset Management System. The Estates Team will appoint for each project, a specialist who is responsibility will be to update the Asset Management System with the final record information. The Building Services Consultant should check and verify that this has been carried out prior to Practical Completion.

All O&M's should be produced in an electronic format that is compatible with the STFC central database.

The O&M's should contain the approved Plant Replacement Strategy developed and maintained as part of the design.

The O&M specialist should retain a copy of all the delivered record documentation for at least one year after practical completion. If requested by STFC during this period, they should provide additional copies subject to a charge.

It should be the responsibility of the O&M specialist and Contractor to undertake the following activities with respect to the preparation of the operation and maintenance manual:

- Liaison with the Principle Designer and any other parties associated with the production of the Health and Safety File, to ensure that the required information is complete and that the method of presentation and terms used are consistent.
- Liaison with designated members of the design team to obtain all information necessary to convey a thorough understanding of the design intent and operating principles of the installations.



- Liaison with designated contractors and specialist subcontractors to obtain all necessary details of the installed systems and equipment to enable safe and proper operation and maintenance.
- Liaison with specialist equipment suppliers as necessary to ensure that clear operating and maintenance instructions are included.
- Preparation of additional written, diagrammatic and/ or pictorial information as necessary for the operation and maintenance of the engineering services installations.
- Re-drafting and restructuring information provided by others as necessary so as to ensure consistency with other parts of the manual and other sections of the Health and Safety File.
- Collating all the information into a coordinated, indexed and cross-referenced document.
- Providing all stationery, printed material and binders required for the production of the draft and final editions of the operation and maintenance manuals.

The O&M Specialist should be responsible for the correction of any errors or omissions in the manual.

A.10.1 General Requirements

All documentation should be in English as spoken and written in the United Kingdom. All units of measurement should be metric, conforming to the SI system.

The text of descriptive sections should be concise and complete avoiding possible ambiguity or misunderstanding. All information should be pertinent to the specific installations.

Irrelevant material or material of a general nature should not be included. Where generic standard clauses are used as the basis for certain parts of the manual, they should be edited to ensure that all text is relevant to the works.

Jargon should be avoided. All new terms should be defined when first introduced. Abbreviations should only be used if they have been defined or their meaning is clear from the text.

The imperative mode should be used for instructions regarding operation, maintenance, disassembly etc.

Illustrations, drawings and diagrams incorporated into the manual should be easily read in conjunction with the relevant text.

All aspects of the manual should comply with relevant requirements of the CDM Regulations 2015 for the provision of information for the Health and Safety File.

Where appropriate, the maintenance procedures and frequencies detailed in the manual should be in accordance with details provided by the manufacturer for specific items of equipment. Where specific requirements are not pertinent, the procedures and frequencies should be as recommended in SFG 20 Standard Maintenance Specifications for Services in Buildings.

Care should be exercised to ensure that maintenance procedures and frequencies described in manufacturers' printed details are accurately reflected in the text of the manual.

The O&M specialist should identify, from the Estates team, the intended maintenance strategy for the

works and the level of technical competence and user ability of the personnel likely to be employed. The manual should be written in a style to suit the abilities of all users. Where necessary, separate sections should be prepared to suit the following levels of competence:

- A. Non-technical – e.g. Building manager or caretaker requiring simple directions for basic operations.
- B. General technical – With broad based maintenance skills required for routine maintenance, inspections etc. and detailed analysis of system operations.
- C. Specialist – Individual fields with respect to particular items of plant

The manual should have an alphabetical index or indexes. The indexing and cross-referencing in other parts of the manual should be arranged to provide easy access to required information.

STFC space location information to align with the STFC Asset Management System.

A.10.2 Content and layout

The manual should be arranged as follows unless an alternative format and contents are agreed with the Estates team prior to issue of the draft document. Suitable alternatives may consist of electronic versions on a CD/DVD or USB/Memory device. STFC require 1 x Hard copy and 1 x Soft copy.

Title pages

- Premises name and address (authenticated postal address, phone, fax, e-mail etc.)
- Services referred to in the manual
- Full name and address of STFC
- Date of completion and date of handover of the services to STFC
- Date of issue
- The author's reference number of the manual
- Name and address of the author of the manual

Contents and index

- Contents list for the whole manual. To comprise a master list of main headings of each section for each volume of the manual, for cross reference. (Copies of this master contents list to be included in the master contents list for the Health and Safety File)
 - Detailed contents for the particular volume. To include a structured contents list showing main headings and details of contents of each section in that volume, with paragraph numbers and page numbers.
 - Detailed contents for each section. To be located at the front of each section of the manual, giving a detailed, structured list of the contents of the respective section.
- Index comprising a comprehensive alphabetical index for all sections of the manual



Section 1 General information and introductory overview

- Full name, address, telephone numbers, website address and email address of the design team and all installing contractors, sub-contractors and specialists for the Works
- Full name, address, telephone numbers, website address and email address of all public utilities and local authorities
- Any limitations on the use of the manual
- Record of amendments to manual schedule (including space for future records)
- Description of how to use the manual
- List of all supplementary documents
- Distribution list and locations of all copies of the manual

Section 2 Contractual and legal information

- Details of ownership, leases etc. defining areas of responsibility for operation and maintenance
- Construction / handover dates including installation start date(s), practical completion date and end of defects liability date
- Details and copies of all manufacturers' guarantees or warranties together with maintenance agreements offered by sub-contractors or manufacturers. Include expiry dates.
- Insurance inspection reports. Documents pertinent to STFC's liability
- Local and public authority consents. To include permissions required for access, alterations etc.
- Safety and fire certificates. Certificates confirming that the premises and installed systems may be safely utilised. These should include examination certificates by competent persons for pressure systems etc., together with written schemes of examination for pressure systems.

Section 3 Health and safety

- Features or characteristics that may produce a hazard. Flammable, toxic or otherwise deleterious substances necessary for the operation of systems; restricted access; pressure systems etc.
- Known hazards against which protection can be provided
- Mandatory requirements relating to safety. To include details of all systems and equipment requiring periodic inspection/ examination/ testing to comply with relevant regulations, approved codes of practice etc.
- Relevant safety precautions. To include procedures to minimise the risk of damage or injury from recognised hazards. Requirements for special manual procedures, permits to work etc.



Section 4 Emergency information

Contact information for:

- Utility supplier emergency services (gas, water, electricity)
- Provider of emergency call out service
- Security/fire systems
- Location of first aid equipment
- Emergency control locations
- Water main stopcock(s)
- Gas shut -offs
- Electricity isolation points
- Specific systems/plant

Section 5 Description of services and design intent

- A schedule of the floor areas of each of the building zones categorized by environmental servicing type
- Description of the whole building and intended use
- Design philosophy including all design criteria
- A full description of each of the installed systems and items of equipment. To include as a minimum a written explanation of the following:
 - Scope
 - Intended purpose
 - Plant and distribution locations; divisions of main zones; etc. cross-referenced to schematics
 - General design parameters
 - Installed capacities
 - System capacities (based on commissioning results)
 - Restrictions of the systems
 - Planned operational efficiency and most economic mode of operation
 - Expected service life
 - Manufacturers information concerning correct operation

Section 6 Equipment schedules

- System by system schedules of all plant, equipment, valves, distribution boards etc. stating as minimum:
 - Component type
 - Unique asset number (issued by Estates) cross-referenced to the record drawings and schedules.
 - System
 - Location
 - Number off
 - Duty and size, f-gas data etc.
 - Manufacturer and supplier
 - Manufacturer's model and/or reference number, serial number and nameplate details
 - Original order number for the particular plant/equipment
 - Asset Capex Value
 - Expected Service Life



Section 7 Systems operation

- Descriptions of the operational and control strategies to include:
- Control and operating strategy for each system
- Outline of general operating mode including summer and winter operation
- Start-up and shut down procedures. Description of procedures for whole system and individual items of plant, from fully off to fully operational, including interlocks etc.
- Interlocks and inter-dependencies between plant and systems. To include pictorial versions.
- Cause and effect operation procedures i.e. fire alarm systems, gas services etc.
- Procedures for emergency shut down and operating procedures for standby plant. Including pictorial version.
- Means of making safe potentially dangerous plant. Including pictorial version.
- Precautions necessary to overcome known hazards when operating each system, bringing into operation all standby equipment included in each system
- Instructions on fault finding and emergency in case of plant malfunction or equipment failure control sequences for all systems installed
- Details of all software provided and procedures for updating and/or modifying software operating systems and control programs
- Instructions for the creation of control procedure routines and graphic diagrams where applicable.

Section 8 Energy management

- Energy management strategy to enable energy consumption to be monitored and controlled.
- Metering philosophy. To include a schedule of the building's energy supply meters and sub-meters, indicating for each meter, the fuel type, its location, identification and description, and instructions on their use.
- Carbon emissions and the comparable performance benchmarks / target figures for energy consumption and energy costs. (Design assessments to be in accordance with Building Regulations)
- The measured air permeability of the building Part L
- Forms for recording plant running hours, energy consumption and energy costs.

Section 9 Maintenance

- Comprehensive schedules identifying maintenance instructions for each item of plant, coordinated from manufacturer's RELEVANT details and recognised industry guidelines to include:
 - SFG 20 frequency and recommended routine maintenance activities
 - guidance on the nature of deterioration and defects
 - dismantling and re-assembly
 - adjustment , calibration and testing
 - special tools needed for maintenance (cross referenced to the particular item)
 - test equipment and auxiliary services
 - Procedures for fault finding and identifying causes of abnormal operation of plant and/or equipment
 - Reference to spare parts/replacements
 - Recommended frequencies and procedures for routine lubrication of moving parts, including specification for lubricant



Section 10 Spares and tools

- Schedule of types of replaceable assemblies, components etc. particular to specific critical plant
- Schedule of specialist tools / equipment particular for specific plant and necessary for undertaking work at height etc.
- Separate parts lists should be provided for each item detailed in the equipment schedule.
- All hardware and operating software x2, and open license on APP's and operation software.
- Schedule of normal consumable items
- Recommended stocking levels for maintenance and asset up-time.
- Schedule of personal protective equipment necessary for operation / maintenance

Section 11 Drawings

- A schedule of all engineering services record drawings for the Works. STFC Estates require digital format in DWG, ReVit and PDF formats. The information to include drawing title, number, source, revision, date, system detail, file/storage location. The schedule to include space to record future modifications and dates.
- An A3/readable size copy of all record drawings together with an index.
- An A3/readable size copy of all plantroom and switchroom drawings, schematics and schedules
- Legend for all colour-coded services
- Schematic drawings of each system, indicating principal items of plant, equipment, valves, etc.
- A schedule of all manufacturers' drawings for the Works. The information to include drawing title, number, source, revision, date, system detail, file/storage location.

Section 12 Testing and commissioning data

- Copy of report(s) confirming that the Works were satisfactorily commissioned signed by a competent person(s)
- Copies of all test certificates, records, commissioning and performance test records for the Works. All certification should be signed and witnessed.
- Method statements for the testing and commissioning procedures undertaken including description of equipment used.
- Copies of calibration certificates for all test equipment.

Section 13 Manufacturers' data

- Schedule of all manufacturers and suppliers indicating company name, address, telephone numbers, email address(es), website address and equipment unique asset number (Sorted in company order alphabetically)
- Product (manufacturer's) data/ literature for all items of equipment and plant installed.
Note - The information shall be project specific and include detail drawings, electric circuit details and operating and maintenance instructions.

Section 14 Materials and substances

- Register of harmful substances. Details of any materials that could be hazardous to health, used in connection with or otherwise relevant to operational or maintenance activities.
- COSHH
- Register of recyclable materials
- Methods for safe disposal or destruction of any parts, materials or components.
- Provide a data sheet for each material known to constitute a potential hazard, with detailed procedures for its safe, authorised disposal.

Section 15 Modification information

- Details of allowances made by plant manufacturer or system designer for modifications
- Provide space in manual to record future modifications.

The manual should conform to the following minimum standards:

- A. The covers should be substantial, of adequate size, distinctive and of sufficient strength to protect the contents for the life of the installation. The method of binding should give a permanent anchorage along the left-hand side whilst allowing the text to be flat without damage to the spine.
- B. The manuals should be prepared on an approved typeface on top quality A4 suitable for direct insertion into the manuals
- C. The front cover and where appropriate the spine, should have the information clearly displayed in permanent lettering.
- D. Dividers between sections should be stepped, overlapping printed card. The divider should be labelled to identify the section of the manual that it proceeds.
- E. All pages comprising the manual should be subsequently numbered according to each section (i.e. section 1 pages numbered 1/1, 1/2, etc., section pages numbered 2 2/1, 2/2etc.).

A.10.3 Checking of Drafts

A draft copy of the operating and maintenance instruction manuals contained in a temporary loose leaf binder(s) should be issued to the Building Services Consultant and STFC Estates team and commissioning manager/competent person for examination prior to the testing and commissioning.

The draft copy of the manual should conform to the required format and contain all the information identified in this specification with the exception of any information not available at that time (such as commissioning results).

Draft versions of the manual should clearly display the word "DRAFT".

A.10.4 Final documentation

Once approved a draft copy should be handed over prior to instructing the employer's staff in the operation and use of the services installations. This copy should contain all testing and commissioning data and test results, actual control set points etc. in draft form.

Prior to practical completion provide the following copies of the final manual which should include all testing and commissioning results and final plant duties and control settings, etc. in a typed form.

- A. The number of paper format copies should be confirmed by the STFC Estates team
- B. The number of copies in electronic format on CD/DVD/USB should be confirmed by the STFC Estates team

All CD's and other electronic forms of delivery media associated with the manual should be clearly labelled with:

- A. A heading stating "O&M manual" and disc number if more than one disc
- B. Details of the premises and systems covered
- C. The issue number of the manual and date of release

A.10.5 Copyright

STFC should have sole copyright to all documents produced specifically for the manual. STFC should be entitled to produce copies of all parts of the manual for its own use.

If the Employer transfers ownership or responsibility of the installations he/she should be entitled to transfer his/her copyright of documents included in the manual. ***Any intellectual property procured by STFC to be vested within STFC.***

A.11 RECORD DRAWINGS

Record drawings of the complete Works should be provided before practical completion.

Record drawings of the final "as installed" layouts should be issued in draft form to the Building Services Consultant and STFC Estates team for examination 4 weeks prior to the testing and commissioning period to allow checking for accuracy.

Record drawings should be prepared on the current AutoCAD format and single PDF as agreed with the Building Services Consultant and/or STFC representative prior to production of the drawings.

All drawings should be suitably layered, with different services on each layer. A detailed list of layers, external references or equivalent (if used) and list of files should be provided with the discs. If the drawings were produced from CAD drawings provided by the Building Services Consultant, the same layering system should be used.

The drawings should be produced in metric units.

Once approved the complete set of record drawings should be revised as necessary to incorporate testing and commissioning data where applicable, and the final set(s) of record drawings and CD/DVD/USB format should be handed over at practical completion.

Issue at practical completion the complete approved package of record drawings in an electronic format

consisting of PDF and DWG.

Any CD should be labelled and jewel cases should be labelled identifying project title, issue date and index of contents.

Valve charts, electrical distribution charts in panels and the like, should be issued for examination at agreed dates to allow adequate time for manufacture and installation prior to practical completion.

Where portions of the work are to be concealed, draft copies of record drawings should be supplied to the Building Services Consultant before the work is concealed in order to facilitate checking and examination.

The record documents should be correlated so that the terminology and the numerical and/or other references used therein are consistent with and similar to those used in the physical identification of component parts of the works.

Each record drawing should show the following information:

- A. The name of the contract and, where appropriate, the zone or floor designation.
- B. Description of drawing, drawing reference and scale.
- C. Name and address of the contractor and the consulting engineer.

The completed drawings should be signed as record drawings.

Each record drawing should be endorsed with the words 'Record Drawing' in the bottom right hand corner adjacent to the title block.

Mark up 'as detailed' details weekly and before any work is hidden from view.

Plant and switchroom drawings, schedules and schematics

The Contractor should provide good quality plant and switch room drawings, schedules, schematics and instructions and hang in the respective plant room or any other appropriate location or where directed by the Building Services Consultant and/or STFC representative.

The surfaces of such information shall be protected by pressure lamination and hung using suitable fixings with the provision of backboards if necessary.

A sample should be submitted for approval by the Building Services Consultant prior to commencing production.

Provide information as stated elsewhere and include:

- All information required under statutory or other regulations.
- Location of all incoming service isolating and metering facilities.
- Emergency operating procedures including details for emergency call out service.
- First aid instructions for treatment of persons after electrical shock.

- Valve schedules showing reference, type, location, application/service and normal operating position.
- Asset management System references.

The above should be submitted for review by the Building Services Consultant. The review procedure should be as for record drawings as stated elsewhere and all items should be fixed prior to practical completion.

FAILURE TO UNDERTAKE THE ABOVE PROCEDURE FOR THE PREPARATION OF RECORD DRAWINGS, O&M'S AND SYSTEM COMMISSIONING/TESTING RESULTS AND LEAVING THE PRODUCTION OF SUCH DRAWINGS /DOCUMENTS TOO LATE IN THE CONSTRUCTION/COMMISSIONING PERIOD WILL RESULT IN PRACTICAL COMPLETION NOT BEING GRANTED BY THE BUILDING SERVICES CONSULTANT AND/OR STFC REPRESENTATIVE.

A.12 BUILDING LOG BOOKS

Building Log Books are required in accordance with section 3 of the Building Regulations Approved Document L2.

The Log Book should be in the format of CIBSE TM31: "Building Log Books and Standard Templates" and should be provided in electronic as well as paper format.

The Contract specification should require the contractor to produce the log book but the Building Services Consultant should provide the contractor with all necessary design information necessary for the contractor to produce a comprehensive document. The information provided by the Building Services Consult should include:

Clearly, there are direct links between the building log book and the operating and maintenance manual, record drawings etc. The building log book information is an additional requirement to the responsibilities for the production of record documentation as stated elsewhere.

PRACTICAL COMPLETION WILL NOT BE GRANTED IF THE REQUIRED INFORMATION IS NOT RECEIVED.

A.13 HANDOVER

As a pre-requisite to Practical Completion in respect of the contract works including all variations or part thereof, demonstrate to the satisfaction of the Building Services Consultant and/or STFC representative that:

- All the contract works are complete. With the exception of minor snags or limited defects as agreed with the Building Services Consultant and/or STFC representative that could be reasonably completed within an agreed programme without causing disruption to STFC's use of the building or part thereof.
- All spares, keys, tools and other consumables as stated elsewhere have been supplied and handed over to STFC.
- The instruction of STFC's staff in the use and correct operation of the installation has been completed satisfactorily. In particular, the demonstration of safety devices and controls.
- All commissioning and testing completed including the issue of a final commissioning reports signed



by the STFC approved Commissioning Specialist, Building Services Consultant and/or STFC representative.

- All necessary certification by STFC's insurers has been completed (if required).
- All approved record documentation including record drawings, operation and maintenance manuals, etc. is received and approved.
- All information required for the health and safety file is issued to the satisfaction of the Principle Designer.
- All necessary Statutory Authority approvals have been obtained and written confirmation received.
- Completion and issue of building log book information in accordance with Building Regulations.

SHOULD ADEQUATE RECORD DOCUMENTATION NOT BE AVAILABLE PRACTICAL COMPLETION WILL NOT BE GRANTED.

A.14 DEFECTS PERIODS NAMED MATERIALS/SPECIALISTS

During the defects period the contractor should price for addressing any issues arising with all systems covered under the works, including the entire system and not just a part of the system which may have been covered by the works.

The contractor should also price for a 12 month maintenance and servicing period of all works (including entire system) in order to maintain plant and equipment warranties. This will also allow for a 12 month seasonal commissioning programme.

Carry out all planned preventative maintenance on all Engineering Services works during this period, including:

- Testing in compliance with statutory requirements
- Routine maintenance inspections in accordance with the O&M manuals
- Replacement of all 'consumables' at no additional expense to this contract
- Recording of all maintenance work carried out
- Monitoring and recording of all energy consumption through this period
- Interpretation of the energy consumption to demonstrate correct operation of the plant
- The requirements of the Building Regulations Approved Document Part L
- Seasonal commissioning

The Contractor will prepare and submit records of failures or malfunctions of any part of the works during the defects liability period, together with details of remedial action taken, subsequent re-testing and the

results.

The Contractor will notify the STFC of damage, failures or malfunctions to the works caused by incorrect operation of the installations, vandalism or other actions by a third party.

The Contractor will rectify all defects due to materials or workmanship or other faults that occur, including those notified by STFC, during the defects liability period with the minimum of delay and at no additional expense to this contract.

The Contractor will inform the Building Services Consultant and/or STFC representative in writing when all defects are finally rectified so that an inspection may be carried out prior to the issue of a final certificate.

A.15 WORKING WITH ASBESTOS

On all projects the aim is for the total removal of all and not the encapsulation of asbestos identified and should therefore form part of the works if identified.

Please refer to the following STFC guidance documents for further information:

- [STFC SHE code 35 - Asbestos management](#)
- Estates Asbestos Registers

NO WORK TO BE STARTED UNLESS A COPY OF THE REPORT HAS BEEN SEEN BY THE PROJECT MANAGER AND ALL PARTIES WORKING ON THE PROJECT.

A.16 HEALTH AND SAFETY

Comply with the requirements of all relevant health and safety legislation and regulations including the Construction (Design & Management) Regulations (CDM) 2015.

Comply with the requirements of all relevant STFC SHE Codes which can be found on the following link [SHE codes](#)

The Building Services Consultant should be responsible for incorporating Safety in their Designs. As part of each stage gate approval process, Residual Risk Assessments should be provided.

ELECTRICAL SERVICES

B.1 ELECTRICAL GENERAL REQUIREMENTS

B.1.1 SUBSTATION DESIGN

B.1.1.1 General

A large private HV network ring exists on Rutherford Appleton Laboratory which is owned and operated by STFC. This network consists of several rings and radial circuits and over 30 substations which are managed by STFC.

Any electrical alterations and/or upgrades that require connection to a substation/main switchroom are to be carried out in accordance with all current regulations and relevant [SHE STFC Safety Codes](#) along with prior approval from the STFC Estates team.

Where HV equipment and switchgear is to be incorporated in the STFC estate the design should include the facility to isolate for either maintenance or an emergency situation. The HV switch should have the facility to earth HV circuits including HV equipment such as transformers and must be located on the part of the network that falls under the responsibility of STFC.

Consideration must be given at the design stage to limit over voltage when the transformer is partly loaded. The high voltage system should be designed to supply low voltage (230/400V) within the upper and lower limits as laid down in BSEN 5160:2010.

All high voltage installation should incorporate an emergency power off button to enable the isolation of the high voltage system in the event of emergency without the attendance of a high voltage senior authorised person. There should also be an appropriate means of testing EPO's without shutting down all supplies. Cast resin transformers need to be fitted with temperature protection and cooling fans.

All high voltage installation should be securely segregated from other plant areas, to restrict access to authorised personnel only.

Where applicable the high voltage and low voltage protection system should be commissioned together with the existing network by a specialist protection engineer to ensure the correct discrimination achieved in a fault condition. Reference should be made to the site wide discrimination study which is held by STFC Estates.

Close liaison with Estates and the supply Authority is important to determining the correct equipment and design configuration of any works associated with HV systems.

Selected products should be suitable for the intended use and environmental conditions likely to be encountered.

Levels of Electromagnet Interference are to be within the guidelines dictated by Public Health England.

In the absence of specific requirements the following guidelines should be implemented as best practice designs.

B.1.1.2 Electrical Design

Single Transformer Substation

- Protection relays fitted to Transformer Feeder such as Sepam T20 or ITL VIP300 (alarm function to be connected to BMS)
- Unit protection fitted as required:-
 - Unit Protection Pilot cables shall be 2.5mm² 7 core XLPE/SWA
 - Where required over long distances cores maybe doubled up to reduce resistance
 - Each Unit Protection circuit shall be on a separate dedicated cable
 - Pilot cables shall be laid between 300-400mm above the HV feeder they control
- Metering fitted to all breakers with Modbus connection (See also section [B.1.13 Electricity Metering](#))
 - Where possible HV Feeders: power meters such as Powerlogic PM800
 - LV Incomers: higher spec meters such as Socomec Diris A40
 - LV Feeders: lower spec meters such as Socomec Diris A20
- 30V Tripping batteries and charger fitted to both HV and LV Switchgear where HV comprises of simple RMU or similar (where required)
- Battery charger supplied directly from LV Bus-Bars (where required) via protection fuses
- Battery Charger alarms to be connected to BMS
- Temperature monitor (such as TEC T154) to be fitted to cast resin transformers giving fan on/off function, alarm, and LV trip operation (alarm function to be connected to BMS)
- Fan driver (such as TEC VRT200) to be fitted where fans are incorporated in cast resin transformers (alarm function to be connected to BMS)
- Cast resin transformer cubicle door to be interlocked with both HV (earthed) and LV Breakers (key from each required to open door via Castell KL Multi-Key Bolt)
- Oil temperature monitor fitted to internal fluid filled transformers giving alarm and LV trip function (alarm function to be connected to BMS)
- Low burn fluid, such as Midel 7131 shall be used instead of mineral oil where fluid transformer to be installed within a building, and should also be considered for outdoor applications
- VT chamber to be interlocked to prevent access unless HV Breaker in earth position (standard Schneider arrangement)
- LV Boards shall be built to Form 4a type 2 or Form 4b type 5 minimum though Form 4 type 6 is preferred (designs below type 6 to be agreed in advance)
- Reduced Energy Let Through (RELT) shall be fitted to all LV Boards fitted with incoming ACB's fitted with protection relays

Dual Transformer Substation

- N+1 configuration
- Bus-Coupling would normally be possible on the HV side
- Bus-Coupling on LV side
- Protection relays fitted to all HV Feeders such as Sepam or ITL relays (alarm function to be connected to BMS)
- No protection relays required on either HV or LV Bus-Couplers
- Restricted Earth Fault to be incorporated tripping LV Breaker and intertripping HV
- HV Breaker trip must inter-trips with LV Breaker
- Unit Protection fitted as required on HV Ring Feeders or dual feeders (Solkor Rf):-
 - Unit Protection Pilot cables shall be 2.5mm² 7 core XLPE/SWA
 - Where required over long distances cores maybe doubled up to reduce resistance
 - Each Unit Protection circuit shall be on a separate dedicated cable
 - Pilot cables shall be laid between 300-400mm above the HV feeder they control
- Metering fitted to all breakers (HV and LV) with Modbus connections (See also B.1.13)
 - HV Incomers: meters including power quality such as Powerlogic ION7550
 - HV Feeders: power meters such as Powerlogic PM800
 - LV Incomers: higher spec meters such as Socomec Diris A40
 - LV Feeders: lower spec meters such as Socomec Diris A20
- 110V Tripping batteries and charger fitted to HV Switchgear (unless otherwise directed)
- 30V Tripping batteries and charger fitted to LV Switchgear (unless otherwise directed)
- Battery chargers supplied directly to LV Bus-Bars via protection fuses and auto changeover unit which will switch to other set of bars in the event of a failure (or can be manually switched)
- Battery Charger alarms to be connected to BMS
- Temperature monitor (such as TEC T154) to be fitted to cast resin transformers giving fan on/off function, alarm, and LV trip operation (alarm function to be connected to BMS)
- Fan driver (such as TEC VRT200) to be fitted where fans are incorporated in cast resin transformers (alarm function to be connected to BMS)
- Cast resin transformer cubicle door to be interlocked with both HV (earthed) and LV Breakers (key from each required to open door via Castell KL Multi-Key Bolt)
- Oil temperature monitor fitted to internally sited fluid filled transformers giving alarm and LV trip function (alarm function to be connected to BMS)



- Low burn fluid, such as Midel shall be used instead of mineral oil where fluid transformer to be installed within a building, and should also be considered for outdoor applications
- VCB VT chamber to be interlocked to prevent access unless HV Breaker in earth position (standard Schneider arrangement)
- Interlocks on all LV Incomers and Bus-Couplers (within each substation) to be coded alike (Castell FK type)
- Interlocks on HV Breakers to be coded individually (Castell FK type)
- Reduced Energy Let Through (RELT) shall be fitted to all LV Boards fitted with incoming ACB's fitted with protection relays
- LV Boards shall be built to Form 4a type 2 or Form 4b type 5 minimum though Form 4 type 6 is preferred (designs below type 6 to be agreed in advance)

Earthing Arrangements

- Site standard earthing system is TN-S
- Neutral-Earth connection within substation needs to be clearly shown on drawings and should normally be within the LV board (with signage to show position)
- Step and touch potentials to be nullified or greatly reduced in the design within the area of the substation and in the proximity of all extraneous metalwork (such as door frames and fences) by using underground tapes
- Substation design should be for a 'cold' site. If this is not achievable, the design for a 'hot' site needs to be approved by the STFC Estates Authorising Engineer
- Earth Mat design shall incorporated two equally sized mats connected back to a common earth bar via links so that each link can be disconnected in turn to carry out an independent test on each half of the mat without totally removing the earth from the substation
- All earth mat pins with clamped connections to have concrete inspection covers
- Earthing drawing to be produced for approval prior to installation
- Drawing showing Earth Mat layout to be included in O&M manual showing positions of all pins and interconnecting tapes/cables
- See also section [B.1.14 Earthing Systems](#)

B.1.1.3 Building Design

- Substations to be as conventional brick structures or if external then surrounded by fully galvanised palisade fencing and covered with suitable canopy



- The option of Cast resin Transformers should be investigated as an alternative to standard oil type transformers where these are a practical alternative due to weight and other factors
- The use of louvered walls and doors shall be avoided for HV and LV rooms
- The use of louvered walls and doors shall be avoided for Transformer rooms especially those containing cast resin transformers which should be fitted with controlled louvres and extract fans. Even for those containing fluid cooled transformers the preference would be for forced ventilation
- Fluid filled transformers shall be installed within bunded areas capable of holding full quantity of fluid. Where these are sited outside the Transformer shall be covered by a high level canopy
- HV Switch rooms shall have two means of escape
- All substation doors to be fitted with door holders (not door closers) so that doors can be latched open
- Door locks shall be Euro cylinders and follow to the site Master Key series (numbers and supplier to be obtained from Estates Services)
- No mechanical plant shall be housed within electrical substations as these areas shall have restricted access
- Low powered tubular heaters to be fitted in substations sufficient to prevent a dew point being reached. Humidity sensors, connected to the BMS, shall be fitted in all areas containing HV equipment
- The lighting scheme shall cover all areas of the substation and designed to give sufficient light for working within cable boxes and other enclosures
- Sufficient space shall be allowed around all equipment for safe access and adequate working areas
- Floors to be sealed and walls painted

B.2 LV ELECTRICAL SUPPLIES

Any works to LV supplies should be in accordance with all current regulations. Throughout the works all parties will liaise together to ensure that the installation is acceptable to the STFC Estates team.

Consultation to be carried out with the following when negotiating a new supply connection:

1. The Supply Authority (where applicable)
2. The Metering company (where applicable)
3. STFC's Energy Section
4. STFC's Property Manager (for lease agreement matters)

The Building Services Consultant should investigate and design for:



- Installed load for an existing facility (where applicable).
- Proposed additional loads.
- Nature and characteristic of proposed loads.
- The capabilities of the existing electrical infrastructure.
- The completeness and security of the existing protective earthing system.
- The load balancing of the existing system discrimination assessment on existing and proposed protective devices on the complete system.
- Metering should use Modbus and be numbered as part of the STFC Estates teams strategy.

B.3 ELECTRICITY GENERATING PLANT

The private generation associated with a CHP system is for base load support and has no allowance for exporting to the Grid. The system will not operate in island mode in the event of the imported Grid supply being totally lost.

Generating plant as standby generation should always be considered where essential services have been identified in a project proposal/brief.

Stand-by electrical generators should comply with BS 5514 and all designs parameters should be agreed with STFC Estates team prior to completion of concept design Stage 3. The generator should comprise of diesel/gas engines.

The system should be fully automatic and should function on a mains fail basis. The main LV switch panel should incorporate necessary mechanical and electrical interlock change over controls. Where the generator is above 500KVa then demand side response should be considered and discussions should be made with all parties.

Consideration should be given to the location of fuel fill points and storage. Sufficient fuel storage to run the generator at full load for a minimum period of 12 hours should be provided.

The standby generator system should include appropriate weather proof acoustic enclosure (for external location), controls, silenced exhaust systems (max 75 dBA @ 1metre), electrical starting system and auxiliary power supplies.

Notwithstanding the financial boundaries, due consideration should be given to other means of achieving standby or alternative supply arrangement. A cost projection plus life cycle cost analysis should be carried out and submitted to the Project manager for consideration.

B.4 POWER SYSTEMS

Containment systems associated with final circuit serving small power supplied should be suitable for the proposed environment, durable and allow for future capacity. Measures to mitigate EMF effects should be implemented in design with consideration of the proposed equipment to be installed.



- System design should be adequate plus allow 25% spare capacity.
- System to be flexible to enable additions / omissions without major disruptions to others.

B.5 FIRE ALARMS, DETECTION AND SUPPRESSION SYSTEMS

Requirements should be read in conjunction with [Appendix F - Fire Safety Requirements V.2.](#) and [SHE code 32 - Fire and emergency Management.](#)

The Building Services Consultant should consult with local councils and STFC Fire Safety Adviser when developing the design and conducting the necessary risk assessment.

In accordance with current regulations, the complete fire safety strategy for the building should be considered by the designer and all necessary works including such aspects as fire stopping and creating fire compartments should be allowed for. Where necessary works in this regard has been identified during the process of design, but is outside of the scope of the project remit, these should be brought to the attention of the STFC Fire Safety Adviser.

Equipment manufacturers/suppliers to be selected from [Appendix D - Preferred Manufacturers/Suppliers.](#)

The specification should cover:

- Type and location of detectors, sounders, control panels, keypads, power supplies and other ancillaries
- Cable type and method of installation.
- Alarm signaling.
- Telecommunications / reporting function.
- Connection of ancillary services.
- Smoke extract systems.
- HVAC systems, Catering Extract, Fume Cupboards, Gas Systems etc.
- Fireman's switches.
- Warning and evacuation signs (to British Standards).
- Other Ancillary services connections.
- Override switch on fire alarm panel to isolate plant, gas valves, fire dampers etc. during testing.
- Facilities for Equality Act alerting and evacuation.

All systems shall be zoned. In the event that the design proposal constitutes a deviation from British

Standards recommendations then this should be agreed with the STFC's Fire/Safety officers and all relevant interested parties. This information should be fully documented on the commissioning certificate. Any works to existing systems must be commissioned by the current maintenance provider.

Fire Alarm ancillaries

Allowance should be made for the integration of the following other services to the fire alarms system:

- Sprinkler systems.
- Fire suppression systems.
- Door closers/door hold-open devices.
- Firefighting services.
- Passenger Lifts.
- Mechanical control panels.
- Security systems.

Note: The interfacing of the above systems should not compromise the reliability and functionality of the Fire Alarms and detection system.

For Data centre/comms room and other high risk areas should be provided with suitable fire suppression systems as required.

STFC has a 24 hour 365 days of the year Security Team which monitors alarm signals. The designer should liaise with the Estates Maintenance manager with regards to requirements for linking the system to this monitoring station.

B.6 LV SWITCHGEAR

All switchgear is specified for Low Voltage installation to comply with all relevant standards.

Switchgear should be complete and whilst designed to maximise the circulation of air for natural ventilation measures should be taken to minimise possible contamination and egress of dust, particles, damp and vermin. Hence IP rating should be specified in relation to the environmental conditions likely to prevail.

Switchboards/switchpanels are to be tested and certified to current regulation with regards to the protective devices and systems employed.

Instrumentation should be in accordance with IEC 51 (BS 89) with controls conforming to BS EN 60947-4-1 and BS6231.

All switchboards, control panels, Motor Control Centres etc., to be designed/specified complete with all the necessary interconnections and switches on busbars, cables, connectors to modularise these systems such that their removal from the complete installation can be carried out with minimal disruption and continued operation of the overall system.

All switchboard should be provided with minimum 25% spare capacity for future expansion. This will include a combination of spare breaker and space.

Complete earthing system to be incorporated on all designs with earthing points clearly identified, testing points and full earth bonding incorporated in accordance with BS 7671. (See also [Earthing Systems](#))

All switch panel construction should be Form 4 Type 6 but STFC will accept Form 4a Type 2 or Form 4b Type 5 which should be provided by one of the preferred manufacturers as scheduled in [Appendix D – Preferred Manufacturers/Suppliers](#).

In meeting the requirements of Building regulations part L2A & B, facilities to provide metering should be incorporated within the panel design as necessary. In addition, all other outgoing ways should be equipped with CT's, "CT shorts" and voltage connection points to enable the installation of future meters as and when necessary. Meters, associated equipment and wiring should be in accordance with STFC's requirements as detailed elsewhere.

- | | |
|-----------------------------|--|
| Busbar Phase identification | - Brown (A), Black (B), Grey (C) and Blue (N) (Neutral) |
| Neutral conductors | - Full size or double neutral as harmonic assessment requires |
| Insulation of live parts | - By barriers or enclosure |
| Busbar size | - To be capacity of at least 20% greater than the design current |

Factory and on site test to be witnessed by the Building Services Consultant and offer made to the STFC Project Manager for a STFC representative to be present. Site built assemblies shall be fully tested before putting into service (including a repeat factory test as appropriate).

Current Transformers should be installed to meter manufacturer's recommendations on all incoming and outgoing ways. These should be wired to suitable terminal units with CT short links mounted on DIN rail.

Where necessary CT's should be installed on Neutral bars to afford full Power quality monitoring functionality of meters.

Electricity meters should be in accordance with STFC meter specification for networked meters. Allowance should be made for the commissioning of the meter systems, constituting of a factory inspection and on-site commissioning. Meter types and network arrangement to be approved by STFC Estates team.

A brief thermal image survey report should be carried out as part of the final submission once system is in operation with end user loads established.

Device Type	Breaking capacity	Number of Poles	Comments
ACB	80kA	4	Discrimination calc's and settings by designer
MCCB	25kA min	3 & 4	Discrimination calc's and settings by designer
MCB	15kA min	1, 2, & 3	Discrimination calculations by designer

Fuse	80kA	N/A	Discrimination calculations by designer
------	------	-----	---

The Building Services Consultant should ensure devices selected are sufficient to withstand a potential short circuit fault at the points of implementation.

B.7 RESIDUAL CURRENT DEVICES

All circuits to be fitted with RCD protection in accordance with BS 7671 (latest edition), with the exception of circuits with loads or other devices likely to cause unwanted tripping due to high leakage currents generated as part of their normal operation. The designer must assess earth fault loop impedance in ensuring RCD operation within the respective reaction time.

Devices should generally be incorporated within distribution boards as RCBO units or alternatively fitted local to area being served, if the nature of use means tripping is likely and resetting of devices can be managed by technical staff within the client department.

The Building Services Consultant should be responsible for ensuring at all time the ADS (automatic disconnection of supply) times are achieved in accordance with the wiring regulations BS7671 whilst employing RCBO and MCCB/RCD systems.

B.8 DISTRIBUTION BOARDS

All distribution boards to comply with BS 5486 and BS EN 60439 generally as surface mounted units or where proposed as flush mounted, designed with adequate and suitable access for maintenance and rewiring. All distribution boards should be lockable.

Allowance to be made for additional earth bar to be fitted in all boards to facilitate meeting the earthing requirements of BS 7671 section 543, and/or any clean earth connections necessary.

Neutral and Earth bars must have provision for the same number of conductors as outgoing ways.

MCB Distribution boards to be appropriately sized and should be capable of have additional protection devices fitted without the need to disconnect the feed. When selecting such equipment the designer should obtain confirmation from manufacturers of their policy to support these products for a minimum of 10 years.

Due to the nature of the site high fault currents are present and should be taken into account during design phase.

Connections to the neutral bar are to be made in such a way that they correspond to the relevant phase.

All necessary barriers to be fitted to enable safe working and prevent the possibility of direct contact.

Manufacturers/suppliers are provided in [Appendix D – Preferred Manufacturers/Suppliers](#).

B.9 BUSBAR SYSTEMS

Should be manufactured from solid drawn or laminated copper representing the 3 phase, neutral supply and earth to comply with BS EN 60439-2.

Neutral conductor to be (minimum) full size as phase conductor, and where significant harmonics is likely to be generated on the system double size neutrals should be allowed for.

Tap-off busbar systems live copper conductors must be fully enclosed and suitable rated for the prospected earth fault associated with that part of the system, assessing the following conditions:

1. Short-time withstand rating
2. Peak current withstand rating
3. Conditional short-circuit rating when protected by a short-circuit protective device.

The Building Services Consultant should be reminded of the need to assess volt drop on busbar systems, obtaining resistance and impedance values from the manufacturer as necessary.

B.10 UNINTERRUPTABLE POWER SUPPLY UNITS

System to comply with BS EN 50091-1, BS EN 50091-2, BS EN 62040 and BS EN 62040-3.

Static and Rotary UPS installation should be assessed on the merits for the installation proposed.

Essential requirements:

- EMC Suppression to IEC 1000 limits.
- Output voltages 380V – 415V, 3 phase at 50 HZ
- Frequency tolerance +1 %
- Power factor correction (min) 0.9
- Incorporation of full bypass system to enable extensive maintenance.
- Remote monitoring shall be available.
- Controls to be open protocol.

Preferred manufacturers/suppliers are included in [Appendix D – Preferred Manufacturers/Suppliers](#).

B.11 TRANSIENT SURGE SUPPRESSION, HARMONIC CONDITIONERS AND POWER FACTOR UNITS

Consideration should be given to the likelihood and extent of electronic noise and their effects on the system as an incumbent part of achieving an EMC compatible system.

The Building Services Consultant should consider the full building application of suppression systems where full rewiring of an existing buildings infrastructure is proposed and/or on new building projects.

Power factor correction units to be allowed on all new supplies. Power Factor units should be suitably sized and automatically switched in banks to ensure a minimum building power factor of 0.97 with all the services operational.

Measures to mitigate the effects of harmonic currents are to be implemented particularly in buildings employing large amounts of harmonic generating loads whilst conducting business critical operations.

B.12 ELECTRICITY METERING

Electricity meters (HV/LV) on dual transformer substations should be installed to all breakers. STFC estates use standard meters for the LV incomers which are Socomec Diris A40 and Socomec Diris A20 on the

feeders. The HV incomers should include power quality such as Powerlogic ION 7550 and Powerlogic PM800 on the feeders.

The Building Services Consultant should make all the necessary arrangements with the respective meter providers for any installation requiring a new connection from the supply authority. It is preferential to meter lighting and power separately. At the design stage a comprehensive meter strategy should be provided by the Building Services Consultant and approved by STFC Energy Manager.

Information on any existing metering system can be obtained from the STFC Estates team. Allowances should also be made for remote monitoring of this system.

STFC in meeting the requirements of Building Regulation part L2A are progressively installing meters on the RDM (monitoring system) that are networked to provide power quality and energy consumption information. The designer should contact the STFC Estates team for detailed information on these meters and this system.

B.13 EARTHING SYSTEMS

Earthing and bonding of systems should be designed and installed to conform to the recommendation of BS 7671 (latest amendment), BS 7430, BSEN 50310, and electricity supply authority requirements with the standard on site being TN-S.

Earthing system must protect electronics by providing a low impedance path to interconnect equipment. Proper cable routing, zoning and shielding are important aspects of the design and have a significant purpose in preventing possible disturbance from electromagnetic and radio frequency interference.

All designs should employ as "best practice" segregation of sections of earthing system to achieve a "clean" and "dirty" system for electronic and motor loads respectively.

Allow for bonding all exposed conductive parts of the electrical installation and all such extraneous conductive parts associated with the structure as necessary.

Earth Mat design shall incorporate two equally sized mats connected back to a common earth bar via links so that each link can be disconnected in turn to carry out an independent test on each half of the mat without totally removing the earth from the substation. All earth mat pins with clamped connections are to have concrete inspection covers. All components of the design e.g. Pins, interconnecting tape/cable etc. shall be included in the O&M manuals which will include drawing/s.

Neutral-Earth connection within substation needs to be clearly shown on drawings and should normally be within the LV Board (with signage to show position).

Step and touch potentials to be nullified or greatly reduced in the design within the area of the substation and in the proximity of all extraneous metalwork (such as door frames and fences) by using underground tapes

Substation design should be for a 'cold' site. If this is not achievable, the design for a 'hot' site needs to be approved by the STFC Estates Authorising Engineer

B.14 LIGHTNING PROTECTION SYSTEMS

Lightning protection design should be in accordance with BS EN 62305 and incorporating all necessary bonding of exposed conductive parts and other systems as detailed therein.

The designer is required to assess the necessity for lightning protection in relation to the surrounding and probability of lightning strike hitting the structure, with a bias towards safety at all times. Electronic Surge Protection (ESP) system should be provided as per the risk assessment.

Consideration to be given to the aesthetic impact, reaction to dissimilar metals and practicality of accessing testing points (all earth pins to have access covers) to be paramount in the application of design.

Where alteration to an existing system is proposed the suitable clamping and coupling accessories should be used and the system re-tested to confirm low impedance readings. Lightning protection system components to be in accordance with BS EN 50164.

Facilities for periodic testing and inspection should be allowed for the design.

B.15 POWER SERVICES

Accessories for small power services should be to BS 1363 and all other relevant standards. Finish for wiring accessories should be approved by STFC.

Wiring of power systems as ring and radial are to be specified with suitably sized cables allowing for containment systems to maintain the physical and magnetic integrity of the circuits. RCD's shall be used on socket outlet rings as stipulated elsewhere.

All ring socket outlets to be provided with dual earthing arrangement and wired in accordance with BS 7671 requirements for high protective conductor currents. Cleaners sockets should be provided at every 15 metre interval for cleaning purpose.

The designer is required to select items of equipment suitable for the environment and purpose of use or outline stringent stipulations where the selection of equipment is included as part of the contractor responsibility.

Circuit protection devices to be as new unless otherwise stipulated with full discrimination calculations carried out and where cascading protection has been designed in, settings associated with adjustable devices to be clearly stated.

Variable speed motor drives for HVAC equipment's should be installed, where possible adjacent to the motor which it controls. Where this is not possible consideration should be given to the EMC screening of the wiring and isolator.

Allow EMI & RF filtering as close to the point of connections for equipment to be protected where this is specified or deemed necessary.

STFC preferred supplier of accessories can be found in [Appendix D – Preferred Manufacturers/Suppliers](#).

Alternative power supplies in the form of battery back-up, UPS's, standby Generators, or alternative source from a different substation or H.V. ring to be given full consideration as design warrants.

Additionally the Building Services Consultant should assess the possibilities for using smaller UPS units, which would be installed as client managed items, local to the equipment or system being served. Where necessary designer should advise on the benefits of such a system to users work process for the STFC Estates team and the STFC Project Manager to make an informed decision at design stage.

All circuits, both sub-mains and final, should be complete with separate CPC.

B.16 WIRING SYSTEMS

Wiring should be of an approved manufacture, continuous and providing sufficient support, spare capacity, screening and earthing where necessary.

Approved systems:

1. Conduit
2. Trunking
3. Cable tray
4. Ladder
5. Basket (for data and fire alarm cabling only)

Systems should be reviewed with STFC before installation. As a guide corridors and back of house areas should be steel screwed conduit containment systems which are more durable, can be used as an earth path and provides better screening properties if installed correctly. Where visible in offices then plastic conduit/containment should be considered for aesthetic reasons.

Under no circumstances should cable be allowed to rest on any suspended ceiling grid/tiles.

Domestic standard "twin and earth" cable is NOT acceptable for STFC installations.

B.17 MONITORED DISABLED ALARMS AND SERVICES

In meeting the Equality Act 2010 and STFC's standards the following should be considered during design and allowed for where feasible:

- Increase illumination levels in circulating areas.
- Mounting heights of accessories in accordance with Equality Act legislation.
- Access facilities including allowing for door hold open devices where necessary.
- Egress facilities via evacuation lift for persons with mobility problems.
- Services for Refuge Areas.
- Induction loops where required.
- Disabled pager alarms system integrated to BS 7807.
- Flashing xenon light on alarm circuit of fire alarms.
- Disabled call systems in toilets and other areas as necessary.

- Intruder and Panic alarms (Installing companies to be NACOSS or SSAIB approved).

The above list is a guide and does not constitute an exhaustive list of requirements. Any alarms at Rutherford Appleton Laboratory from the above list should be connected to security in R75.

B.18 INDUCTION LOOPS

Audio Frequency Induction Loop Systems (AFILS) should be designed and installed to conform to BS 7594 BS 6083 IEC 118 Part 4.

A conformance certificate should be issued on completion, clearly stating the dB level of the AFILS and any adverse characteristics of the installed system.

Where a Disable pager panel is to be installed on a Fire Alarm System both the power supply and signal link must be monitored.

For systems that require linking back to the Comms Room monitoring station a normally closed volt free relay contact should be allowed on the control panel.

Liaise with the STFC Estates team for wiring and point of interfacing information.

B.19 LABELLING OF SERVICES

The following should be adhered to for new installations and a sample of the labelling shall be provided and approved prior to final installation on site.

The labelling for distribution systems should be carried out with engraved traffolite Black on White, fixed with plastic rivets or nylon screws and in accordance with [Appendix C - Electrical Nomenclature \(RAL\) V2](#).

Tap-off boxes to have ref. identification only.

Other systems to be labelled:

- All socket outlets and power disconnectors – labelled with circuit ref.
- All conductors in distribution boards, MCC etc. to be labelled with termination ref. preferably ferrule or ring type.
- All fire alarm equipment with necessary addresses, device numbers and zones.
- All emergency lighting addressable luminaires with addresses etc.
- All emergency luminaires identifying them as emergency lights with asset number.
- Any other control / monitoring system that required peripheral connections to be identified.

LV Cables

For single phase supplies the phase conductor should be labelled L1, L2 or L3 as Table 51 of BS7671.

Where existing cables are to be re-terminated on a newly installed system, the individual cores should be sleeved with heat shrink with the new colours at the termination points and alphanumeric labels applied.

Label sizes and text heights to be sufficient to be able to identify cables without exposure to live parts. All labels are to be at frequent intervals which should be appropriate to the length installed.

All cables sheaths should be Low Smoke Zero Halogen (LSOH) and should be BASEC approved and this should be clearly identified on the cable drums.

All other labelling in accordance with BS7671 should be applied as necessary.

B.20 LIGHTING

Lighting luminaires to conform to BS EN 60598.

CIBSE lighting Guide recommendations should be employed for obtaining a good standard of design.

Designs should also conform as far as they are applicable to the following Guidance and Limitations:

1. Building Regulations (Part L2A)
2. BRE (BREEAM)
3. SLL (Society of Light and Lighting) CIBSE Code for Lighting
4. BS EN 12464-1
5. The Equality Act

The Building Services Consultant should be aware of imminent industrial changes to the recommendations and standards and where prudent allow for such changes within their design. The lighting strategy is to be agreed with the STFC engineer during the design stage.

Appropriate maintenance factors as recommended by CIBSE will be considered for the lighting calculation. Light levels to be checked after initial lamp lumen in accordance with CIBSE/SLL recommendation.

B.20.1 LED Luminaires

LED lighting should be used on all projects with a cost/energy benefit analysis to be undertaken and presented to the Estates and Sustainability teams for approval.

The level of natural light introduced into the space by windows, skylights and other sources should be assessed. Where appropriate, means of increasing natural light into all areas should be implemented.

Lighting systems should make effective use of the natural light available via the use of day lighting control systems.

A background light level in accordance with the Electrical Services section of this guide should be provided by means of artificial lighting.

Where higher light levels are required, such as on laboratory bench tops, the Building Services Consultant should ensure that this requirement is met by task lighting and socket outlets or fused spurs should be positioned to facilitate this. LED lamps should be used in all desk / task lamps.

Any proposed LED lighting product drivers must be constructed as SMD (Surface Mounted Devices) or COB (Chip on Board Devices). THD (Through Hole Devices) are not acceptable and should not be specified.

Where LED products are being proposed for general lighting solutions, the Building Services Consultant should primarily consider products where the luminaire construction is such that the LED light drivers can be removed without removing the complete luminaire. LED luminaire should have a minimum power factor of 0.7.

The Building Services Consultant should be required to satisfy his/herself with the "binning" approach of the manufacturer, and their approach to future replacements, will provide considering consistent colour rendering of same specification products.

LED luminaires, where possible, should be employed for applications where supplementary decorative lighting or other purpose lighting (such display lighting) is required. The designer shall carry out necessary lighting design calculations, obtaining photometric data from manufacturers as necessary. The low energy consumption properties of LED products make them an attractive option; but the Building Services Consultant should ensure the products selected are practical, robust, easily replaceable and achieves the light levels required. Allowance must always be made for the possibility of premature failure of these products, ensuring access and a maintainable solution is part of the design.

LED light drivers or module should produce a consistent 3000K colour of light with no apparent variation between fitting either upon installation or afterwards. The heat sink should work passively and maintain the LED connections and circuitry at the proper temperature to ensure their full life. The LEDs should have a life of no less than 50,000 hours and not lose any more than 70 % of their lumen output after a period of 3 years.

For maintenance factor assessment the designer should apply 3 year duration between luminaire cleaning.

Manufacturers/suppliers are listed in [Appendix D – Preferred Manufacturers/Suppliers](#).

B.20.2 Lighting Control Systems

Control of lighting should enable user interface as well as provide energy conservation in relation to daylight contribution and occupancy. It is strongly recommended that design proposals for automated controls are approved by lighting controls specialist to ensure complete coverage and reliable operation.

Control Systems should:

Be operating on digital control protocols such as DALI.

Lighting control systems to be open protocol for future maintenance and alterations by STFC Estates staff.

Incorporating bus cabling and driver devices, linking all lighting control devices.

Employs microwave sensors for more reliable detection where this is possible.

Implement Corridor linking and Daylight sensing.

Utilise digitally dimmable control gear in luminaires to regulate light output and maximise energy efficiency.

Interface with AV systems.

User interface should be allowed, either in the form of remote handheld devices or wall mounted switches compatible with the system. Final requirement should be agreed with STFC Estates team.

Record information of the lighting control system should be included on drawings, and should consist of Addresses, zonal information, device locations, cable routes and an indication of the control strategy.

Digital DALI lighting protocols now provide a common platform for system to be developed around employing intelligent control ballasts with individual addressability and should be utilised where possible on designs.

B.20.3 Exterior Lighting

All foot paths, walkways communal areas, car parks, access roads and external plant areas associated with new or existing must be provided with adequate exterior lighting to meet all applicable local authority and building control requirements.

Street lighting should be LED and conform to BS5489 (Code of Practice for the design of Road Lighting). Please refer to Appendix B - Street lighting.

Switching for exterior luminaire should be in groups utilising the BMS and should incorporate an override facility for maintenance purpose. All exterior lighting scheme/s must utilise LED to minimise operating and maintenance cost over the full projected life cycle of the installation. The external lighting design should consider the security standards regarding CCTV, control points etc.

Lighting solutions should ensure that illumination is considered not just on the horizontal working plain but also effective vertical illumination of the space and ensuring uniformity utilising spacing to height ratio figures provided by manufacturers.

Sample luminaires and data sheets should be provided to the project team for inspection before final approval of any manufacturer's product.

B.20.4 Specialist Lighting

All lighting designs associated with the floodlighting of buildings, theatre lighting of stage areas, and feature lighting of moving objects or water features should be referred to a lighting specialist with proven track record.

Photographic Darkrooms should be fitted with tungsten halogen or GLS lamp luminaires for general lighting to eliminate possible afterglow issues commonly associated with discharge lamps.

B.20.5 Emergency Lighting

STFC's requirement is to have open protocol LED standalone addressable emergency lighting in lieu of central battery system. Any deviations to this must be agreed with STFC Estates and will only be considered where a separate system could adversely impact or not be practical solution.

Non-maintained luminaires should be installed as standalone 3 hour duration units obtaining live feed from the local associated lighting circuit.

Conversion/combined emergency luminaires shall not be installed, except for the following exceptional conditions. In each one of these conditions, the designer must seek specific written approval from STFC Estates:-

Areas with high ceilings and where wall mounted emergency lights would not meet the requirements.

High Profile aesthetically pleasing areas where a standalone emergency light would adversely compromise the effect of the space or not be a practical solution (i.e. listed buildings). In these instances, small recessed LED's must have been considered and discounted prior to seeking approval for converted/combined Luminaires.

Where space restrictions dictates in listed buildings retaining a certain period feel.

Emergency units to be incorporated within luminaire or remote mounted only on luminaires that are mounted in accessible suspended ceilings.

LED emergency lighting must be installed as the STFC standard, however where LED lighting may not be suitable traditional light source may be considered.

For refurbishment projects the contractor/design team should carry out necessary survey to establish the existing interface and testing facility and protect the integrity of existing loops. The appropriate solution shall be compatible with the testing system being employed throughout the building.

Emergency Lighting Testing Systems

Testing systems should be in accordance with BS 5266. Addressable testing system should be as a STFC approved system installed fully to the manufacturer's recommendation and in accordance with STFC's policy:

Manual test key switch system (preferably ganged with the local light switch control or located at the distribution board positions), shall be provided where an automated addressable testing system neither exists nor is proposed as part of the project specific brief.

Emergency Lighting Addressable System

Open protocol addressable emergency lighting testing systems have been installed in a number of buildings and the policy is to extend the coverage where possible.

Where systems do not exist the Estates Team Leader (Electrical) should determine the requirement for the project, and which system to be installed.

Where a system exists the designer should allow for their adaptation for the new proposals, and should liaise with the system manufacturer to develop the design and work elements.

In all cases where works are carried out on the system, commissioning back to head end PC on the main site is required, with handover constituting:

A fault free 3 hour duration test on system (and printout where necessary).

CD with set-up and back-up files of the system as commissioned.

Commissioning Certificates and Check list.



Record information should include drawings with addresses, device numbers, and/or group numbers; indication of routes of communication cabling plus other associated equipment.

The designer should also allow for the installation of data socket adjacent to the control panel of these systems and advise Estates of the port numbers to enable STFC to arrange configuration of the IT network, for secure communication to the remote PC.

MECHANICAL SERVICES

C.1 MECHANICAL GENERAL REQUIREMENTS

The following criteria have been provided for guidance only. The Building Services Consultant should ensure that all design criteria are compliant with all current mandatory standards and are in line with the recommendations of CIBSE guides, BSRIA or other such recognised industry bodies. Any deviation from these standards and guidelines should be identified and agreed with the STFC Estates team prior to commencing the design.

C.2 UTILITIES AND INFRASTRUCTURE

Buildings should be provided with a metered incoming water supply from the Statutory Authority's or STFC network. New meter positions should be agreed with the Estates Management Team. The meter should be pulsed to allow for BEMS monitoring of consumption. Where the meter is located remote from the building boundary, a second client check meter with BEMS connected pulsed output should be provided and the flows compared to act as leak detection. The BEMS should also use intelligence to determine demand patterns over time and identify out of range use.

Where gas is required, buildings should be provided with a main incoming gas meter and governor in a ventilated room including high and low level ventilation in accordance with IGEM and Gas Safe Regulations. The meter and shutoff valve should be fully accessible from the front.

The gas meter should be capable of accepting up to 120% of the design load. All meters should be low pressure drop and pulse connection to the BMS system. All gas solenoid valves should be low pressure drop and comply with the Gas Installation Regulations. Use of boosters should be avoided where possible.

All gas running within buildings should be ventilated either via suitable high and low level grilles in risers which link to an external space or where this is impractical, via pipe in pipe installation.

C.3 PIPEWORK SYSTEMS

No plastic pipework systems should be specified for any heating, cooling or domestic hot and cold water systems, except in specific laboratory applications.

Alternative materials or systems such as thin wall stainless steel may be considered through prior agreement with the STFC Estates team.

All pipework insulation should be installed by the pipework installation subcontractor and not the lagging subcontractor complete with clear external identification, to include:

- Service identification
- Direction of flow
- Un insulated pipework dimension

Prior to the start of a project the Building Services Consultant should obtain a Legionella risk assessment for all existing systems from the STFC Estates / maintenance team.

A water hygiene review should be carried out at Stage D with a detailed review and verification of the Consultants design by a STFC approved specialist and the system treatment and maintenance regimes presented to the STFC Estates team for comment and approval prior to proceeding to detailed design. The dosing of systems with chemicals should be avoided wherever possible with specific attention being given to the overall system filtration/strainer requirements. Consideration should be given to equipment

warranties.

Transducers should be specified on all secondary circulation pumps and other main plant items to monitor water flows through BMS alarms in order to assist with proactive maintenance regimes.

Binder test points should be provided on all systems for testing, sampling and commissioning purposes, specific to the monitoring of calorifiers / storage vessels water temperatures for system analysis.

Dead legs should be avoided on all pipework systems (New or refurbishment works).

If required under BREEAM, all toilet facilities, cleaners' cupboards and catering areas should be provided with automatic motorised shut off valves on the cold water supplies linked to presence detection. This function should incorporate the full requirements/specification identified under BREEAM.

All heating and chilled water systems should provide accessible shut off facilities to all floors or appropriate zones for system maintenance, leak isolation or future fit-out activities.

Provision for expansion and contraction of pipe services should be designed and detailed on the tender drawings rather than covered by a general clause in the specification. The preference is to build in expansion loops and natural flexibility as opposed to using bellows (expansion joints).

C.4 HEATING, BOILERS AND HUMIDIFICATION

Preferred systems are high-efficiency condensing boilers which are fully automatic in operation and connected to the BEMS. Energy efficiency and lifetime costs should be the guiding principles in the selection of system type and equipment selection. Systems should be designed with adequate provision to maintain suitable heat output in the event of a failure of a single item of heating output. This will generally require a minimum of two boilers rated at 66% of design load or three boilers at 40%.

The preferred system will utilise direct boiler flow temperature modulation and maximum use of condensing modes particularly within new build projects. Return temperatures of 30°C- 40°C are preferable but must be considered in relation to the size and cost of heat emitters.

Any condensing boilers should be fitted with neutralisers on the condense and discharge to manufacturers guidelines and current regulations. These must be easily accessible for routine maintenance. The condense pipework must be designed to prevent freezing in cold weather e.g. the provision of tundishes within plantrooms and any external pipework to be insulated.

Boiler selection should seek to achieve class leading reduction in emissions ($\text{NO}_x < 40\text{mg/kWh}$) and high overall efficiencies. All plant and equipment should be selected to operate within acceptable noise levels. Each gas fired boiler should be able to modulate and turn down to a minimum of 20% of the maximum output and accept a variable volume flow. The gas fired boilers should have stainless steel heat exchangers, a large internal water capacity and should be capable of operating with a variable flow volume.

Ventilation to boiler plant rooms should be provided at high and low level in accordance with BS 5440 or BS 6644 where applicable. Boiler flues should be stainless steel, twin walled and insulated and should be fire rated for 2 hours at 300°C for the entire length. Flues should be provided with trapped drain for rain water and condensate, which should be taken back to the nearest gully in the plant room and safely discharged.

In some instances, the use of heat pumps may be an appropriate source for heating and/or cooling. Either

air-source or ground-source heat pumps may be considered, however close attention must be paid to the COP and SEER of the unit by selecting appropriate operating temperatures. Ground source heat pumps should have a minimum COP of 3.5 in heating mode.

Where ground source heat pumps are used, it is important to ensure that there is either a balanced heating or cooling load or that the ground is suitably recharged over the year (for example by using solar collectors to deposit heat into the ground in summer for predominantly heating systems, or by using dry coolers to reject heat in winter during predominantly cooling systems).

Detailed consideration should be made to the interface between the ground source heat pumps and the Trend BEMS system.

Plate heat exchangers may be required to separate external glycol circuits from systems within the building. All glycol systems should contain food-grade glycol.

Space heating should generally be by radiators with thermostatic radiator valves (TRVs) to BSEN215-1 and BS7556 on a variable temperature (VT) circuit. Radiator valves should be lockable, and tamper/vandal proof. The STFC Estates team will identify suitable new positions for any control equipment and sensors in the building.

VT circuits should be provided with independent run and standby pumps complete with variable speed drives. Systems should be split into primary and secondary systems where local plant incorporating multiple boilers is used.

Heat emitters within disabled toilets or similar areas (Nursery) should be of the low surface temperature type with a maximum surface temperature of 43°C.

Where fan coils or fan convectors are proposed, fans and motors should be mounted on a chassis independent of the convector casings. The motor should be positioned prior to the convector element to eliminate damage by excessive air temperatures. Fan convectors should be served by constant temperature circuits only.

Valved flushing loops should be fitted at all fan convectors and fan coil units. Fan coil units should be complete with internally fitted thermostats and low temperature cut-out switches. In-line strainers should be fitted before all control and isolation valves on fan coil units. Access panels should be provided to facilitate easy maintenance of filters, motors, control valves etc. Internal filters should be fitted and have an atmospheric dust spot efficiency of at least 55% when tested in accordance with BS 6540. Control should be by interface units to the BEMS system.

Use of humidifiers should be avoided where possible; however where the internal environmental conditions require the use of humidity control, the preference is to use resistive steam type as opposed to electrode boiler due to the reduced maintenance and spares costs. It may be necessary to provide Reverse Osmosis (RO) water to the humidifiers. Where in-duct humidifiers are installed, ensure the downstream absorption distance is sufficient; typically 1.5m. On larger installations, consider the use of gas-fired humidifiers rather than electric in order to minimise the electrical load.

All fuel sources should be evaluated in order to attain the most efficient and cost effective heat source for the project. The successful application depends on the type of heating system to be used: condensing boilers are effective with under floor heating, and weather compensated variable temperature circuits.

The Building Services Consultant should:



- Use weather compensation of flow temperature if radiator systems are used.
- Consider the use of Combined Heat and Power where high annual hours use is expected of a building (more than 4,500 hours per year), and there are high demands for heating and hot water.
- The size and location of heat emitters in the office space should take account of the heat loss and ventilation requirements of the space.

Where the works involve the installation, removal or relocation of partition walls, the Building Services Consultant should:

- Review heat losses from the areas affected by the works
- Review heat emitter capacities in relation to the new heat loss
- Review air movement within the space to ensure that newly enclosed office areas have an appropriate heat source and are neither over-heated nor under-heated, taking account of changes in heat load caused by a change in the rate of supply of fresh air.

As a result of the above reviews the following actions may be required:

- Heat emitters should either be removed or new ones installed.
- The heating system should be rebalanced to enable the new heating requirements to be satisfied.

The provision of electric heating should be provided only as a last resort. Where electric heating is installed, it should be provided with tamperproof temperature and time programmed controls. Electric heating in cellular offices or areas of intermittent occupancy should be fitted with automatic presence sensing controls or run back timer.

New pipe work, vessels and other items for space heating systems should be insulated in compliance with the British Standards.

Insulation may not be necessary where the heat loss from the pipe is useful in heating the surrounding space.

C.5 HOT AND COLD WATER SERVICES

C.5.1 Hot water

Systems should be designed in accordance with the Water Regulations 1999, CIBSE TM13, HSC guidance L8 and [STFC SHE code 38 - Legionella](#).

User Departments should be consulted to establish the minimum number of hot water outlets required in a laboratory, as a hot supply is not always required to a laboratory sink. The laboratory hot water for small projects can be served by local electric water heaters connected to the category 5 boosted cold water, unless there is an existing category 5 HWS system available for connection. Where a larger number of laboratory outlets justify the requirement for central category 5 HWS plant, then this should be totally segregated from the category 2 supplies with separate secondary cold feeds and circulation pipework.

Hot water to washbasins in disabled toilets or general use areas should be provided with thermostatic mixer taps limiting the temperature to 43°C at the outlet. Hot water supplies to laboratories and staff accommodation are not considered "public" areas and do not require this control. Such sinks should be clearly labelled "Caution - very hot water".

Consideration should be given to the specification and use of thermostatic mixing taps wherever possible in lieu of blending valves in order to avoid unnecessary dead legs.

All water services branches should be provided with pressure regulation to limit pressure and control fluctuations where the static system pressure exceeds 2.0 bar. Where extending from existing HWS circulation pipework, the new pipework should be of the same material as existing to avoid dezincification. Galvanised steel pipework should not be installed in STFC buildings and all existing removed wherever practicable and/or economical. Plastic pipework systems will not be considered unless by approval of the STFC Estates team or for specialist requirements with labs etc. All other pipework systems should be either copper or steel.

Stainless steel braided EDPD (or similar) flexible hoses **should not** be used for final connections to outlets unless agreed with Estates and WRAS approved.

Deadlegs should be avoided where control sensors or thermometers etc. are installed. Transducers should be provided on the delivery side of the pump to monitor operation via the BEMS.

Services should be labelled "cat 2 water" or "cat 5 water"

Hot water should be provided from unvented storage water heaters with provision for renewal services connections i.e. heat recovery etc.

Condensing direct gas-fired storage heaters are available, and the economics of their use should be appraised. Where hot water use is expected to be low, for example just a hand washing basin, the use of electric instantaneous heaters or low volume electric storage heaters for localised supply will be considered.

C.5.2 Cold water services

Systems should be designed in accordance with the Water Regulations 1999, CIBSE TM13, HSG guidance L8 and [STFC SHE code 38 - Legionella](#).

Boosted water sets should be installed in all new building projects. Any refurbishments should be reviewed and appropriate services put in place to work with the existing cold water strategy.

Booster sets should include duty/standby pumps as a minimum with IE2 or IE3 motors and auto changeover. Booster sets should be provided with a control panel, and connected to the BEMS.

Water consumption can be less than that indicated by design guides and interpretation of occupancy levels from room data sheets should be used to highlight hygiene risks due to low turnover of stored water. Water cisterns should be sized in the normal way but fitted with Aylesbury "KB" type delayed action float valves with adjustable water and differential levels. The levels should initially be set at lower than the listed actual capacity of the cisterns and should be adjusted to suit actual turnover under "in-use" conditions.

Tanks should consist of pre-insulated sectional GRP panels. All tanks should have a minimum of 900mm clear above for access and should be installed on plinths a minimum of 500mm high. Access should be via external galvanised steel ladders and internal stainless steel ladders. Screened vents should be minimum 100mm diameter.

In new buildings the cold water storage for laboratory and for domestic use should be totally segregated in accordance with the water categories.

Where buildings or areas are being refurbished all redundant pipework shall be removed back to the last

live pipework and a through joint used wherever practicable.

In existing buildings the extent of the segregation should be discussed with the STFC Estates Team to agree what can be reasonably achieved within the cost restraints of the project. The minimum requirement should be to segregate the water services in the new project area even though these might be connected to a common point outside the project area. This will provide a ready point of connection when services to the remainder of the building are brought into line with the regulations.

Although the risk assessments for a particular project may identify laboratory use water as category 4, all laboratory use water (except wash basins in laboratories) should be designed as category 5. The reasons for this are:

- RPZ valves are not acceptable due to the costs to maintain these on a register and the ongoing maintenance liability.
- Laboratory use can change within a short time and flexibility of use is required.

The wash basin provided in a laboratory for use at point of exit should be served with category 1 domestic water.

Where extending from existing CWS circulation pipework, the new pipework should be of the same material as existing to avoid dezincification. However, galvanised steel pipework should not be installed in STFC buildings and all existing removed wherever practicable and/ or economical. Plastics pipework systems will not be considered unless by approval of the STFC Estates team for specialist requirements with labs etc. All other pipework systems should be either copper or steel.

Stainless steel braided EDPD (or similar WRAS approved) flexible hoses **should not** be used for final connections to outlets.

A suitable water treatment system should be specified in agreement with the STFC Estates team where required.

Services should be labelled accordingly.

All drinking water outlets should be supplied directly from the mains supply. Back flow prevention should be provided as necessary. Where water pipework runs externally, it should be trace heated.

C.5.3 Water Conservation

STFC is conscious of its environmental responsibility in respect to water conservation. Designers should:

- Use electronic sensor taps or timed turn-off taps in toilets.
- Use 'water-saver' showerheads where applicable.
- Use occupancy sensing flush controllers for urinals, and consider interlocking occupancy sensing to toilet lights.
- Use dual-flush WC suites with clear instructions on the method of operation on the cistern or nearby.



- Specify drought-resistant plants, and grasses suited to dry conditions when landscaping.
- Consider the use of 'grey water' recycling for toilet flushing. Special consideration should be given to the recycling of waste water from reverse osmosis water plant.
- Consider the use of rainwater collection and storage systems.
- Ensure recirculating chillers are used for process cooling demands within the project area to prevent the use of mains water to drain wastage.

C.5.4 Above Ground Drainage

It is recommended that an intrusive CCTV survey is undertaken on any existing building and associated drainage system including utility sewer connection outlets in order to define a full scope of works and risk assessment. Any remedial works to existing systems should be agreed with the STFC Estates team.

The above ground foul drainage systems should be installed to discharge all waste and effluent via gravity from all sinks, FF&E, sanitary fittings, kitchen appliances and any mechanical plant/equipment etc. Pipe work should be routed down through the building to ground level to connect to the below ground drainage system. The system should be a modified one pipe partially ventilated system.

All internal vertical soil/waste vent pipes and foul water drainage pipes passing through occupied areas outside the main service risers should be insulated acoustically. Access should be provided on all vertical foul drainage stacks at 1200mm above each finished floor level, to the centerline of the access door and on horizontal pipe work in accordance with the requirements of the Building Regulations and BS EN 12056-2.

All DX Units, fan coil unit and air handling units should be provided with gravity condensate drainage where possible, with the required air break detail.

Where laboratory drainage is provided, this should carry chemical laden waste water including fume cupboards, laboratory benches, equipment, floor drains, etc. for final discharge into the below ground drainage system. The designer should check with the relevant department for information on the substances to be used with the drainage to ensure correct material selection. Typically, Vulcathene or similar drainage will be appropriate. The main ventilating pipe work should be installed to suit the design of both the above ground laboratory drainage system and the below ground drainage systems as necessary and should terminate to atmosphere.

Rainwater systems should typically comprise gravity systems and these should be generally be collected from roof areas by a combination of rainwater outlets and gutters with downpipes. Pipework should be routed to discharge flows via gravity, vertically down through the building.

All services passing through building fabric should be sleeved and insulated, and should be continued through the building fabric. All pipe work and equipment must be earth bonded. Access should be provided on all vertical internal rainwater pipes at 1200mm above each finished floor level, to the centerline of the access door and on horizontal pipe work in accordance with the requirements of the Building Regulations and BS EN 12056-3.

Gradients of all rainwater pipes should be a minimum of 12mm/m, but should be to suit the individual flow characteristics of each rainwater pipe, to achieve a minimum self-cleansing velocity.

Consideration may be given to the use of a syphonic rainwater system in conjunction with the Architect

and input from a specialist system supplier.

Suitable access provision should be allowed for throughout the building and the system to allow for adequate maintenance which should include for consultation with the STFC Facilities Department to determine any specialist traps and grease removal management.

C.6 CHILLED WATER AND COOLING

The STFC policy is that cooling systems should only be provided where absolutely necessary. Natural ventilation should always be used in preference to mechanical ventilation. Designs should incorporate free cooling and /or night purge cooling wherever possible.

Where there is equipment, process or scientific need for a controlled temperature environment of either less than 21°C or to within a control band of +/- 1°C from a specified temperature, the provision of cooling should be considered and the following points taken into account:-

- The client department should be requested to reduce or relocate a number of pieces of equipment with high heat dissipation from their brief.
- The client department should review the energy efficiency of the equipment intended for the space with the assistance of the Building Services Consultant, with a view to decreasing equipment heat dissipation into the space. This should include specification of technologies such as flat screen PC monitors, shared printers and dedicated photocopier rooms.
- Natural ventilation provision to the space should be reviewed.

Central packaged chillers should generally utilise scroll or multiple screw compressors and designers should require tenderers to identify the COP at design conditions as well as EER/SEER as part of the tender submission. Chillers should be provided with electronic soft starters or other low-current starting device. Buffer vessels should be provided to minimise starts at low load conditions. BEMS control should include operational status, on/off and CHW modulation.

Friction free, magnetic bearing (TurboCor type) chillers may be considered for reduced energy costs and carbon emissions on agreement with the STFC Estates Team and the STFC Maintenance Team.

Care must be taken to assess the effect of plant failure and maintenance on serviced areas, and any necessary contingency provided. This risk assessment is particularly relevant to animal areas and/or critical operational areas e.g. main computer server rooms, where the maintenance of specified temperatures is either legislative or operationally required. Such considerations should include 100% independent back up with auto changeover, remote alarm of high temperature and/or plant changeover to a continuously manned monitoring position and UPS/standby electrical generator.

CHW should be split into primary and secondary circuits. The circuits should be provided with independent run and standby pumps complete with variable speed drives and 2-port control valve in an injection circuit.

Valved flushing loops should be fitted at all terminal units. In-line strainers should be fitted before all control valves. If fan coils are used, these should be complete with internally fitted thermostats and low temperature cut-out switches. Access panels should be provided to facilitate easy maintenance of filters, motors, control valves etc. Internal filters should be fitted and have an atmospheric dust spot efficiency of at least 55% when tested in accordance with BS 6540. Control should be by interface units to the BEMS system

The provision of cooling to server rooms, IT hubs and freezer equipment rooms etc. where cooling load would not be proportional to external temperature should be selected with care. These areas are also operational on a 24/7 basis and cooling equipment must be selected on the basis high CHW flow temperatures. Generally these areas should be provided with air supply to utilise local free cooling.

Small areas or specific equipment requiring localised cooling may be served by DX split equipment. Designers should require tenderers to identify the COP at design conditions as well as EER/SEER as part of the tender submission. These units should be monitored by the BEMS system and leak detection should be provided to all refrigerant systems with consideration given to automatic pump down. Consideration of the consequences of equipment failure is essential.

Where central chiller installation is either not viable or feasible in terms of size, weight, loads or acoustics, consideration can be given to the use of Variable Refrigerant Flow (VRF) systems.

All refrigerants should be zero ozone depleting with low global warming potential. At design Stages C and D consideration should be given to the appropriate refrigeration specification with a detailed feasibility report being produced which identifies the advantages and disadvantages of each refrigerant. This report should be presented to the Estates and Sustainability teams for comment and approval prior to proceeding with the design.

Where extending from existing chilled water circulation the use of the original system component types should be considered to reduce the risk of interaction between dissimilar metal materials. Where separate new plant and pipework is provided then ABS, stainless steel, or copper should be used as appropriate.

Cooling should only be considered on written request from the Head of the Client Department to the STFC Estates team.

Where the STFC Estates team approves cooling, it should be achieved in accordance with the cooling strategy for the building in which the works are taking place.

Where modifications are made to existing space cooling systems they will result in compliance with the minimum Building Regulations Part L efficiencies.

The Building Services Consultant should:

- Design air flow rates that are large enough to enable the air supply to meet the space cooling loads when used as a cooling medium.
- Ensure only areas that are authorised for the provision of cooling are served by the air supply to be cooled.
- Where available ensure chilled water is used to cool the air supply.
- Always consider the inclusion of heat recovery.
- Only consider direct expansion 'split units' in buildings with limited cooling application and where this is appropriate to the building's cooling strategy and electrical supply capacity.
- In order to achieve the benefits of energy saving, low maintenance and occupier comfort, inverter controlled compressor systems should be specified for DX cooling systems.

- Consider the use of time control, seven day and run back timers to limit the unnecessary use of cooling out of hours.

The STFC Estates team should be consulted with regard to the locations available for DX split units.

Consideration should be given to fire risk, obstruction of fire escape routes, noise nuisance, vibration noise nuisance, visual intrusion and structural strength of the building fabric at proposed locations for condenser units.

The lack of consideration of some of the above points has historically led to significant problems in the management and operation of refrigeration equipment for STFC Estates in the past.

C.6.1 Equipment Cooling

Where scientific equipment requires process cooling then this should be provided by closed circuit systems incorporating a chiller (or a plate heat exchanger if central chiller plant is available). Buffer vessels should be incorporated to provide stable temperatures. Where removal of residual heat from equipment is required in the event of electrical or chiller failure then an automatic, standby, water to waste, system utilising normally open and normally closed solenoid valves should be considered after discussion with the STFC Estates team.

User Departments should be consulted to obtain installation requirement data for the equipment to establish:

- Heat gain
- Min/max water pressures
- Tolerance to back pressure (e.g. some electron microscopes will not operate if the outlet back-pressure/static lift exceeds approx. 3 metres head.)
- Flow rate
- Whether tap water or treated water fill is required (e.g. de-ionised water may require special components)
- Required cooling water flow temperature to avoid condensation
- Whether there is a requirement for removal of residual heat from equipment in the event of electrical or chiller failure.

C.7 ISOLATION VALAVES

Isolation valves should be detailed at main pipework junctions and at all branches from risers to enable future adaptations without the need to isolate large areas of a building.

All items of plant should be fitted with isolating valves as should components which may require removal for maintenance such as strainers.

Commissioning valves and other throttling valves must not be used for isolation there must be a dedicated isolation valve.

The consultant should ensure that all isolation valves are checked and adequately tested/proven during the construction, testing and commissioning stage.

C.8 VENTILATION

C.8.1 Natural Ventilation

The successful use of natural ventilation depends on the geometry of the building, internal heat gains, building usage, local air quality and acoustic constraints.

STFC design preference is to use natural ventilation over air-conditioning or mechanical ventilation. Designs should incorporate free cooling and/or night purging where possible.

Buildings which rely on natural ventilation can have high summer ventilation rates with no energy penalty. Summer ventilation rates may need to be ten times greater than those achieved in winter to avoid overheating.

Buildings which are designed to use mechanical ventilation should use heat recovery during the heating season and natural ventilation from opening windows during summertime. During the heating season, the windows should be locked shut or have interlocking controls to avoid heating when the windows are open. If this is not possible the most efficient system to provide the environmental conditions should be designed and approved by STFC Estates.

Natural ventilation can be provided from windows, ventilation slots in window frames, solar-driven stack-effect or from purpose made controllable through the wall systems. Thermal comfort may also be influenced by the exposed thermal mass of the building: a lightweight building will respond rapidly to changes in external conditions, whereas with a heavyweight structure a noticeable damping effect on internal temperatures may occur. The use of suspended ceilings effectively removes the thermal mass of the floor slab from the thermal response of the building, allowing more rapid variations in temperature.

All areas should be naturally ventilated by means of trickle vents or open-able windows, as appropriate to achieve a minimum air change rate of 8 l/second per person wherever possible.

The Building Services Consultant should:

- Note that STFC expects the maximum use possible of natural ventilation in all its buildings.
- Ensure that the thermal mass of the building can be used to minimise summer overheating.
- Consider the use of 'Mixed-mode' ventilation systems with heat recovery.
- Consider the use of external solar shading to minimise summer overheating.

C.8.2 Mechanical Ventilation

Mixed mode systems should be considered where natural ventilation is insufficient to ensure comfortable internal conditions throughout the year. This will include an extract fan which is operated when certain internal conditions are reached, with make-up air typically via automated façade ventilation. It is preferable that each space has its own extract fan to avoid scenarios where unoccupied rooms are overcooled in the mid-season due to the adjacent room being occupied and triggering mixed mode operation.

Heat recovery should be provided on all supply and extract systems where appropriate. Preference should be given to high efficiency systems such as hygroscopic thermal wheels (80%+ efficiency) followed by non-hygroscopic (70%+ efficiency), plate heat exchangers (50%+ efficiency) then followed by heat pipe/runaround coils (40%+ efficiency). Fully modulating motorised bypass dampers should be provided

on plate heat exchangers.

Generally, ventilation fans should be centrifugal, of the backward bladed type with a fan total efficiency of not less than 50%. Where fans are belt driven, a minimum of two belts should be used. Particular consideration should be given to Specific Fan Power (SFP) of mechanical ventilation installations, particularly in new build projects. Direct drive plenum fans may also be considered.

All fans should be provided with variable speed drives. In new buildings, design of systems including heat recovery should aim for a minimum Specific Fan Power (SFP) to provide compliance with the current Building Regulations. Within existing buildings where riser or distribution routes are constrained, this may be relaxed.

Maximum velocity across cooling coils in AHUs should be 2.0m/s and all coils must be provided with trapped condensate drains. All AHUs should be compliant with CEN class L3 or greater for leakage.

WC's should be provided with extract ventilation and make up air should be either via undercut doors or grilles. If this isn't feasible then the use of supply make up air will be accepted. Make up air should be supplied at 85% of the supply rate to ensure negative pressurisation. Consideration may be given to constant pressure systems whereby the fan provides trickle extract during unoccupied periods and ramps up to full extract for a pre-set period when occupancy is sensed via PIR. Run and standby twin fans with auto changeover should be provided on WC extract systems.

All ductwork manufacture and installation must be in accordance with DW144.

Commercial kitchen extract fans should be interlocked with the gas supply to ensure that gas is not supplied to the room when the ventilation system is not in operation.

Suitable attenuation should be provided to all ventilation systems. The maximum pressure drop for primary attenuators should be 50Pa and crosstalk attenuators should be no greater than 10Pa. Consideration should also be given to suitable sizing of weather louvres where used such that velocity and pressure drop are not excessive; typically less than 4m/s face velocity and 50Pa pressure drop or lower depending on noise criteria.

Within laboratories mechanical ventilation should be designed as a full fresh air system with heat recovery where appropriate (e.g. heat recovery from fume cupboard and safety cabinet exhausts is not considered appropriate). Thermal wheels and cross flow plate heat exchangers are preferred to heat pipes and run-around coils.

Laboratories should generally be designed to operate at negative pressure (i.e. greater extract than supply) for containment. Where there is a specific requirement to design a laboratory for positive pressure for cleanliness then this should be referred to Estates and Facilities for approval. If this is accepted then a lobby should be incorporated to provide containment and to prevent spread of smoke and fire to corridors and means of escape.

In areas control of humidity should normally only be provided if specifically requested.

Supply air diffusers should be designed and located to minimise air movement at the face of fume cupboards and microbiological safety cabinets which would otherwise have an adverse effect on containment.

Supply/make-up air systems for local exhaust systems (fume cupboards etc.) should be controlled such that this is isolated when the local exhaust system is off to avoid pressurising the room. Where

appropriate, systems should include constant volume devices to maintain the system balance when interlocked make-up air supply branches are isolated.

All air handling units should consist of the following components as appropriate:

- Twin wall insulated frames
- Pre-filters to unit and heat exchanger, secondary bag filters
- Heat recovery (thermal wheels, cross plate and run around coils)
- High efficiency, variable speed fans
- CO2 control
- Chilled water or DX cooling coils
- LTHW or gas fired heating coils
- Inspection sections for maintenance
- Inspection windows
- Internal and external lighting complete with manual local switching

All air handling systems should be fitted with a full set of clean filters and provided with a full set of new spare filters at handover. The O&M manuals should contain a separate sheet listing the number, size, and type of all filters so that this information can be readily accessed to update at a later date.

Transducers for the monitoring of air flow on all fans and filters should be provided and interfaced with the BEMS system.

The impact of the installation, removal or relocation of walls, doors, windows etc. upon ventilation requirements and provision should be carefully reviewed by the design team to ensure that all areas receive the appropriate air supply.

If the existing provision is determined to be either inadequate or excessive to meet the post-refurbishment needs of the space, the existing systems should be modified to meet the new ventilation requirements.

Where an existing mechanical ventilation system is being substantially altered, or new systems installed the specific fan power (SFP) should meet the minimum efficiencies and specific fan power levels as specified under Approved Document Part L.

The STFC Project Manager and Estates team should be consulted with regard to all modifications to existing and new mechanical ventilation services as described within this guidance document.

C.9 COOLING TOWERS AND DRY COOLER

Air blast and adiabatic air blast (dry) coolers should be employed where practical but, subject to

consultation with the STFC Estates Team, adiabatic cooling and cooling towers can also be considered.

On smaller dry coolers, EC fans should be used where economically viable. Noise from dry coolers should be carefully considered when locating them. Operating efficiency of dry coolers may be improved in some circumstances by using evaporative cooling meshes on the air intake path. Several dry cooler manufacturers are able to provide such systems to suit their own products.

Where cooling towers are specified, there are many factors to consider and in particular, care must be taken to prevent the presence of legionella at all cost. Maintenance requirements are significant and therefore dry cooling systems may be preferable. Key design aspects include:

- Water treatment – Scale inhibitors, side stream filtration, biocide dosing etc.
- Location – prevention of recirculation, noise, plumbing, distance from air intakes
- Winter operation - sump heaters
- Capacity control - variable speed fans
- Noise Attenuation
- Access - ladders and inspection hatches
- Local Authority requirements
- Structural implication

Maintaining the ventilation, cooling and humidification to these areas is critical and where stand-by power generation is available the AHU's should be arranged to operate in the event of mains power failure. This requirement would not generally extend to the associated chiller plant due to the high power demand of such plant but the User Department should be consulted. The AHU's should be provided with duplicate components to maintain the ventilation but this need not necessarily mean duplicate 100% duty plant but could be designed to maintain say 66% duty on failure of one component. Boilers and chillers should comprise modular components and standby pumps etc. should be provided to maintain reasonable conditions in the event of failure of one item of plant.

Terminal reheat designs are preferred for good humidity and temperature control. Hot and cold dual duct systems are not generally acceptable.

C.10 BUILDING ENERGY MANAGEMENT SYSTEM

Unless projects are of a minor nature then all new buildings or major refurbishments should be specified with Trend controls and be in accordance with this document and [Appendix A - STFC BEMS specification](#).

All BEMS controllers shall be TREND IQ4E-IP Ethernet, with BacNet for major plant control. Other TREND controllers for fan coil units etc. should use IQeco or similar TREND controllers where possible. We have a limited number of IP addresses so this must be noted at the start of the project and discussed with Estates. Riello Premium Pro or similar Eaton UPS units will be incorporated in all BEMS control panels.

There should be no PIN or passwords set on the system so that Estates have full access and can setup our

requirements.

Where packaged plant manufacturers (chillers, AHU's, fan coils etc.) have developed full interface controls to Trend these should be used in preference to plant that requires interfaces to "talk" to other control protocols such as LON-works. Provide full control functionality between such packaged plant interface controllers (not just on/off/common alarm functions)

Provide interactive graphics for each control loop, item of plant etc. with knobs and switches to fix an output to a set value; manually over-ride on/off and auto changeover control; amend time schedules; reset software latches. Graphic format should be as current STFC systems and controls specialists should be instructed to contact STFC Estates Team to arrange to view current graphics and factory testing. The BEMS graphics should be included within the technical submittal for sign off by the STFC Estates Team prior to delivery to site.

Configure logs on all points to provide 3 days history to assist trouble shooting.

There are four groups of alarms which are listed below. STFC Estates team must see a list of alarms before handover. Groups of alarms are:-

Group 1	Maintenance	Priority 0
Group 2	Plant	Priority 74
Group 3	Critical	Priority 140
Group 4	Security	Priority 170

Set up web pages on integral web servers of controller for access to interactive graphics via Internet Explorer from a remote PC.

Provide strategy diagrams in paper copy in O&M manuals and on CD in electronic format for record purposes and future adaptations.

Areas such as lecture theatres and seminar rooms subject to intermittent use should incorporate a form of occupancy control for energy efficiency. This should generally be in the form of a time-schedule to operate the plant for a minimum period to pre-condition the space and occupancy sensors to switch the plant to full speed.

Control panels should incorporate fire alarm circuit interlock relays and lamp test buttons. Provide relays to selector switches to give a common alarm to the BEMS when one or more panel selector switches are in "hand". Provide switched socket outlet on side of panel.

Panels should be in standard grey finish. Panels should generally be form 2 (separate power and control section) with MCCB's (type D where appropriate), and 15% spare backspace for expansion. Critchley type ferrule markers should be used to identify all terminations in the control panel and at plant and equipment in the field.

C.11 CONTINUOUS AND OUT OF HOURS OPERATION

Where a room or area such as an equipment room or constant temperature room requires continuously operating cooling or heating then consideration should be given to the provision of independent plant rather than connecting to central plant, to avoid extended operation of a larger, central, system which could otherwise be controlled by a time schedule.

Where a Lecture Theatre or similar facility is likely to be used or let for use beyond the normal time

scheduled hours of operation for the building in which it is located consideration should be given to the provision of independent plant to avoid extended operation of the whole building. Where appropriate separately time controlled zoning may be employed to achieve this requirement.

The STFC Estates team should be consulted on this issue at design stage.

C.12 FUME CUPBOARDS

Fume cupboard installations should comply with BS EN 14175. The supply and installation of fume cupboards generally forms part of the construction contract.

Ensure liaison with all parties to ensure that the requirements of the fume cupboards are met. Test certificates should be submitted to the STFC Estates Team on completion together with advice of any existing fume cupboards removed. This information is essential to maintain the fume cupboard register required by legislation.

Sash to be combination vertical and horizontal sliding (saves energy when work can be accessed through one door only)

Fume cupboards in different laboratories should not be interconnected. They must be run to the discharge level independently.

Multi-cupboard installation Fume cupboards from a single Laboratory, to be VAV controlled with sensors to determine both vertical and horizontal sash opening positions. Exhaust system to be designed for 100% diversity. VAV controllers to have max response time of 3 seconds and to interface with make-up air controller. Fume cupboard to have proximity sensor to close sash after pre-determined absence time (variable up to 15 mins with sensor to stop sash if obstructed). Main exhaust fans to have VAV controlled ambient air intake to maintain required efflux velocity.

Simple face velocities measured at a grid in accordance with BS EN 14175 will suffice for site tests of single conventional cupboards. Maximum/minimum face velocities across the measurement grid should not deviate from the average by more than 20%. Full containment tests are required on site for multi-cupboard installations in accordance with BS EN14175.

Fume exhaust fans should generally be direct drive units with inverter control for commissioning purposes.

Fume exhaust ducting should generally be installed in chemical grade PVCu ducting with the external sections GRP coated for mechanical protection and to reduce solar degradation.

Fume exhaust systems must be independent and NOT combined with any other general extract ventilation systems.

Discharge stacks should be a minimum of 3 metres above the immediate roof level or, where a nearby roof level is within a 15 metre radius on which maintenance or other personnel will stand, then 3 metres above the higher roof. Discharge stacks should terminate with a high velocity cone giving an efflux velocity.

Fire suppression systems should be fitted to all chemical fume cupboards. Details of the allowance and arrangement to be agreed with STFC's Fire Safety Manager.

C.13 CONTAINMENT LEVEL 3 (CL3) LABORATORIES

Where identified as a containment level 3 laboratory this should be designed to the requirements of CL

of "The management, design and operation of microbiological containment laboratories" by the Advisory Committee on Dangerous Pathogens (ACDP)

Estates and Facilities should be consulted to discuss STFC specific requirements for these laboratories. These requirements include:

The exacting standards of workmanship and design necessary to achieve a room which is completely sealable, without re-entry, in the event of an emergency fumigation being necessary following a spillage or similar accident. Service entries to be sealed with formaldehyde resistant mastic and ventilation ducts to have motorised gas tight dampers.

Provide duplicate extract fans, with automatic non-return dampers, to ensure that an inward airflow to the laboratory is maintained during work with pathogens. Duty share changeover should take place by running both fans simultaneously before dropping out the duty fan.

Pressure regimes to be designed to the requirements of the occupying department and all relevant regulations. These should be controlled and regulated using pressure weighted non-return air transfer dampers.

Extract fans to be wired to a maintained supply where available.

Extract fans to be inverter controlled, with velocity sensor control, to maintain the design extract rate as HEPA filters become dirty.

Provide HEPA filters in any extract connections from the laboratory where not already included as part of a safety cabinet exhaust.

Provide a safe change HEPA filter in the extract at the common point of exit from the laboratory or in the ducting before the extract fan set. This is for additional protection of maintenance staff working on the remote extract fans etc.

Where possible, all maintainable plant should be located outside the laboratory.

Make up air supplies should be fitted with non-return dampers to prevent reverse airflows and constant volume devices. Supply diffusers should be designed to avoid draughts across the face of microbiological safety cabinets, which might otherwise effect containment.

Supply fan to be interlocked with extract fan such that extract must be proven to run before enabling supply. This can result in high negative room pressures at start up and the designer should ensure that the Architect is advised of the resultant loadings on the structure (particularly relevant to suspended ceiling support).

Microbiological safety cabinets to be connected to extract system. These are to be arranged to continue to operate in the event of main extract fan failure and alarms should be provided with a clear label to advise that users should carry out an immediate controlled shut-down of work.

Provide electrical isolation for the microbiological safety cabinets in the lobby outside of the laboratory.

Provide pressure differential alarms, clearly labelled, to advise the users if the negative pressure is not maintained. A time delay should be added to allow for opening of door for entry/exit. Provide magnehelic gauges for ready visual indication.

Locate control panel for category 3 system in lobby/prep room for operation of systems in emergency, including control of fans, motorised dampers etc. The systems should operate "on demand" at the local panel and not be over-riden by a time schedule on the central BEMS. The BEMS should be configured for monitoring only of this panel.

Ventilation to be designed for full fresh air. Extract rate to exceed make up air rate and to be greater than sum of microbiological safety cabinet exhausts. Rates to be increased if necessary to allow sufficient air changes to deal with room cooling loads.

Provide 10mm (100 mm long maximum.) test port through laboratory door, with cap on lobby side, for testing for residual formaldehyde following fumigation.

Carry out smoke tests on completion to validate air-tightness for fumigation.

Consult with users to establish whether lone working is anticipated and provide "lone working" alarms as appropriate.

Provide gas tight dampers in ducting outside the laboratory for fumigation and ensure that no non-airtight items such as heater batteries are positioned on the laboratory side of these dampers.

C.14 PLANT MAINTENANCE

The first year maintenance of "primary plant" within the defects liability period should be included within the project. This is particularly relevant to plant where the guarantee is dependent upon a prescriptive maintenance schedule such as chillers, boilers, compressors, etc.

C.15 WATER HYGEINE RISK ASSESSMENTS/METHOD STATEMENTS

To satisfy the provisions of the Health and Safety at Work Act and specifically L8 -The control of legionella bacteria in water systems – STFC will not accept handover of the installations until full and adequate information concerning the installations, which will include chlorination certificates if applicable, is in the possession of estates.

The Building Services Consultant should specify that the contractor should employ a specialist to carry out risk assessments of the water systems and to prepare a method statement, for inclusion in the O&M manual, for maintenance of the control of legionella bacteria.

The risk assessment should cover the whole of the systems in new build situations and where dedicated systems are installed to serve a refurbished area.

During refurbishments where the existing systems are adapted then the risk assessment should comprise of a review/revision of the current assessment and method statement for the building.

C.16 PLANT AND SERVICES ADJACENT TO PROJECT SITES

Roof works on new projects should take full account of existing services on the same or adjacent roofs. An example would be where existing fume extract discharge stacks may need to be raised to comply with the clearances stated elsewhere in this document and existing fresh air inlets may be affected by new fume exhausts.

Where construction of a project may affect the maintenance, operation and reliability of existing plant

then risk assessments should be carried out and appropriate measures specified and costed in the project. Examples would be:

Arranging to turn off air handling systems if possible where dust or fumes are generated by the works and/or changing of air filters every 2 weeks whilst such work is in progress.

Protecting existing condensing units or chillers whilst still allowing sufficient free air flow and cleaning of the condenser coils during and after such work.

All works should be included in the project costs and not left to STFC Estates to fund.

C.17 PRESSURE GAUGES AND THERMOMETERS

Regardless of the fact that systems may have sensors giving readings to a BEMS system pressure gauges and thermometers should be provided to facilitate maintenance and fault finding.

Pressure/altitude gauges should be fitted to at least the inlet and outlet of circulation or booster pump sets, heat generation plant, buffer and expansion vessels.

Thermometers should be fitted at the very minimum to each storage vessel, chilled water F&R, heating F&R, heat generating plant, HWS F&R, supply and fresh air ducts and extract ducts where recuperation is employed adjacent to air handling units, and in cold water storage tanks.

C.18 ELECTRICAL POWER SUPPLIES TO PUMPS

Where practical final power connections to pumps should be made using commando type sockets with integral isolator switches to enable ready disconnection and removal by maintenance fitters without the need for the attendance of an electrician.



APPENDIX A – BEMS SPECIFICATION

BMS CONTROL PANEL - STANDARD SPECIFICATION.

All in house built BMS Control panels have a standard specification with regards to components and wire colours and control strategy.

During design stage when the number of input/output points is calculated a minimum of 25 % extra will be allowed for future expansion.

The new control panel should be fitted with an IQView 8 touch screen display.

Within a control panel, all MCB and contactors shall be manufactured by Schneider Electric, as will all switch gear components.

All control relays shall be the Finder range, type 95.06 modular relay, type 94.04 4 pole relay base, type 94.03 3 pole base with appropriate finder suppression modules.

Terminals within control panel shall be ENTRALEC SNA series.

Panel indicator lamps shall be Schneider Electric, Harmony LED series XB4, 24v AC for control circuits, 240v ac Mains.

Colours shall be Green for 'Enabled', Red for 'Power on', Yellow/Amber for 'Fault' and Blue for 'water/air flow.

All panels will incorporate 'lamp test' button.

All equipment where possible will have 'Hand' 'Off' 'Auto' control switches. All control panel wiring should follow a site standard - see attached document. 'Hand' operation will mean independent of BMS control.

Cabling between control panel and other equipment shall be contained in metal cable tray or trunking. Short flexible conduit routes allowed. CY type cable can be used on cable tray or trunking, Beldon multicore shall be used for signal/low voltage (24v AC power, 0-10v dc control) Tri-rated singles cable shall be used in control panels and field wiring.

Multi pumps will have 'Duty Select' when in Hand.

All heating boilers will have remote enable and fault contacts to enable them to be controlled by BEMS.

All panel control design layout shall be approved by Estates services before manufacture.



DRG: WIRE COLOURS,
1 of 1
DATE: FEBRUARY 2012







**STANDARD WIRE COLOURS AND TERMINAL
NUMBERING FOR CONTROL PANELS**

CIRCUIT N^o

WIRING COLOURS

	L1 BROWN		24v AC CONTROL -SWITCHED PINK
	L2 BLACK		24v AC CONTROL - YELLOW
	L3 GREY		0v COMM CONTROL - GREEN
	NEUTRAL- BLUE		DIDGITAL INPUTS - ORANGE
	UPS L1 - RED		UPTO 24v FROM EXTERNAL SOURCE - PURPLE
	UPS NEUTRAL - WHITE		EARTH, CHASSIS – GREEN/YELLOW

WIRE SIZE

	24v AC CONTROL 0.75mm ²	POWER* L1 2.5mm ²
	0v COMM CONTROL	POWER* L2 2.5mm ²
	DIDGITAL INPUTS 0.75mm ²	POWER* L3 2.5mm ²
	EXTERNAL CTRL/SOURCE 0.75mm ²	POWER NEUTRAL* 2.5mm ²
	UPS L1 1.5mm ²	EARTH/CHASSIS* 2.5mm ²
	UPS NEUTRAL 1.5mm ²	

* UNLESS POWER LOAD IS GREATER

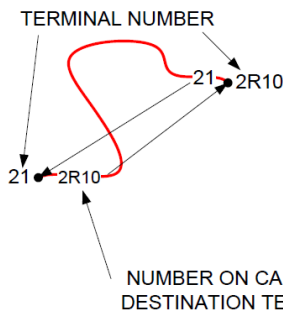
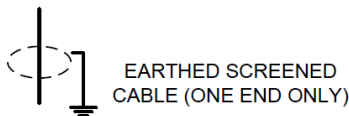
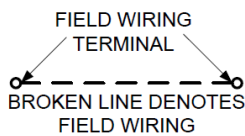

CABLE MARKER EXAMPLE 1:
2R10
2 = TERMINAL NUMBER
R10 = DEVICE NUMBER 10, R = RELAY

CABLE MARKER EXAMPLE 2:
A1C2
A1 = COIL TERMINAL ON
C2 = CONTACTOR 2

TREND MODULE
INTERCONNECTING
CABLE LAYOUT
(TYPE A: LEFT to RIGHT)

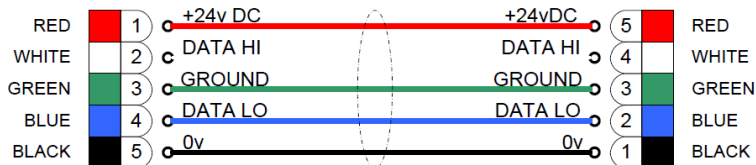



DRG: TCH SEMINARHEATING
HTG PUMPS
1 of 10
DATE: MARCH 2015

NAME
PUMPS, 24v CONTROL CIRCUIT. (PAGE 2)
AUTO-OFF-HAND CTRL

CIRCUIT N°

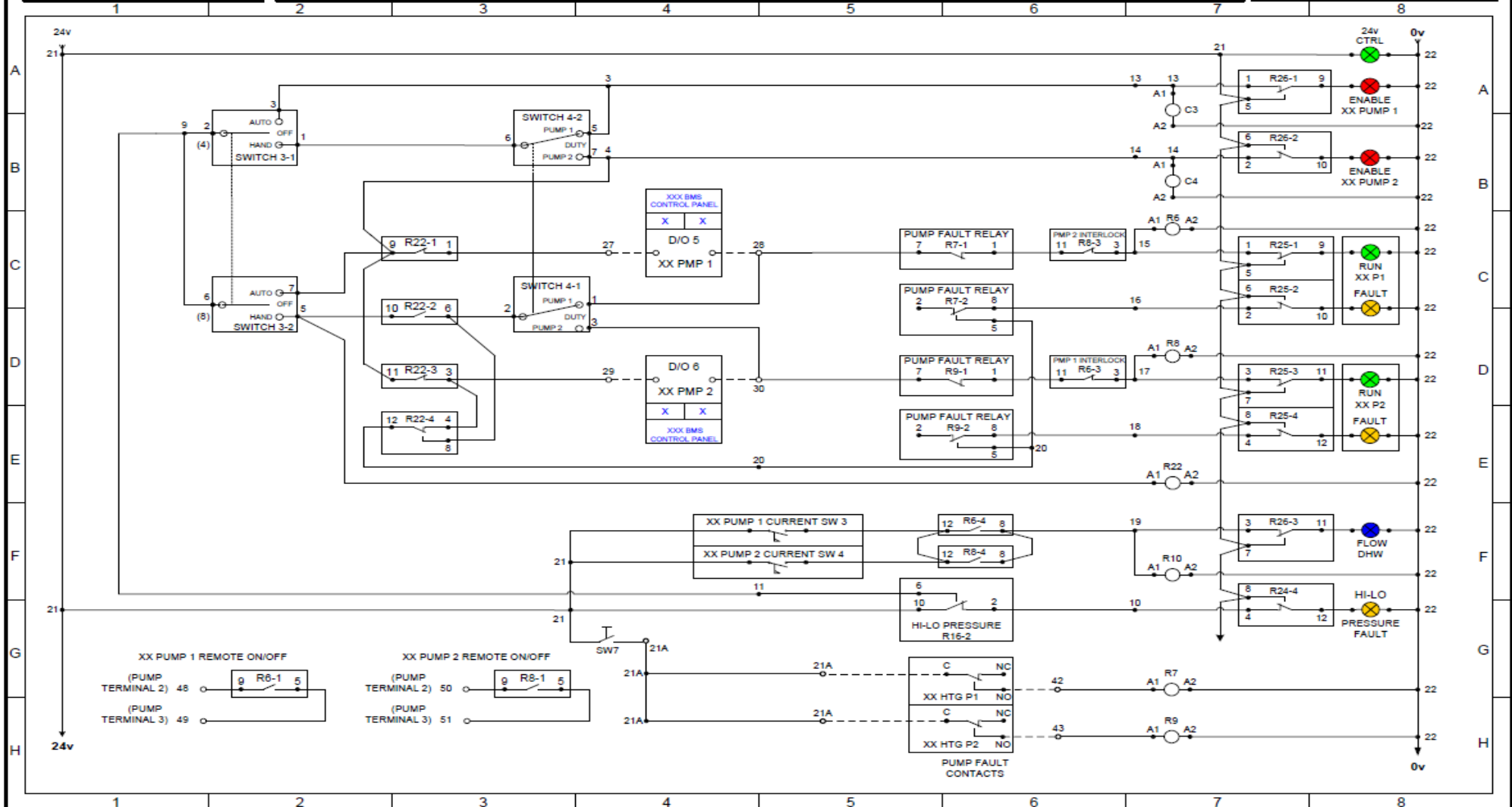



APPENDIX B – STREET LIGHTING

Positions of Street Lighting Columns

Columns shall be positioned to ensure that the lighting scheme provides the best coverage of the adoptable highway area. The designer shall avoid placing columns in corners, on traffic islands, or where light may be a source of light pollution or distraction. Column location within the adoptable footpath shall not unnecessarily cause obstruction to the passage of pedestrian traffic.

Note: The exact positions of all lighting columns must be agreed on site by the Project Manager before erection work commences.

Electricity Supplies

Services to the lighting columns will terminate in a cut-out situated the base of each column. Where the column is positioned between the supply point and the final column on a circuit, both cables shall be terminated at the cut-out for ease of fault finding.

Earth Electrodes shall be installed to meet the requirements of BS7671. This may be achieved by installing an earth electrode at any feed point supplying more than two street lights.

Street lights shall be controlled in the following ways:

- a) All Night: these are controlled directly from the central photocell through the BMS and are switched on at dusk and off at dawn;
- b) Part Night: these are controlled directly from the central photocell through the BMS and are switched on at dusk and off at dawn, however an override controlled by the site Building Management System will turn these lights off for a prescribed period during the night where there is minimal traffic.
- c) Building Lighting: these are controlled directly from the central photocell through the BMS and are switched on at dusk and off at dawn, however an override controlled by the site Building Management System will turn these lights off shortly after the building has been vacated at night, and back on shortly before normal resumption of work in the morning. These timings may be specific to the building.

The positioning of All Night columns shall be such that bends in the road, junctions, pedestrian crossings, and all other hazards are illuminated throughout the night. A consideration in some areas may need to be made to ensure a certain amount of safety lighting is also maintained, especially in footpath areas. Traffic signs and bollards shall also be illuminated under All Night conditions. Non-critical lighting shall be controlled as Part Night.

Description of the type of cable to be used, the method of installation, and glanding. Types of cut-out for single, twin (loop in, loop out), and triple (loop in, loop out, and spur) cable connections. Also we need to define the type of cable to be used supplying the lantern, the size of fuse or, in the case of MCB's, the type.

The type of lantern needs to be described in all cases (columns, bollards (pedestrian and traffic)).

Testing and Installation Records to be provided

The completion of the work includes the testing of the installation to the satisfaction of the Project Manager and Estates Services. Completed test certificates for each installation shall be provided to the Project Manager by the installer, together with a complete schedule detailing all the installed electrical equipment, including all illuminated signs and bollards. The schedule shall confirm installed details of column type, lantern type, control type, column number and installation date. A numbered installation drawing shall also be provided showing the final scheme.

Street Lighting Columns

All street lighting columns and bollards shall be numbered as shown on the drawing. The numbers shall be describe format adopted for current numbering.

All columns and brackets (where required) shall be of plain tubular steel cross section and shall conform to the requirements of British Standard BS 5649 (EN40 Parts 1 to 6). K-factor for wind loading shall be 1.8. All columns shall be finished hot dip galvanised to BS 729 (EN ISO 11461) with a minimum thickness of 85 microns.

Structural design of all street lighting columns shall include for a sign of 5kg weight and 0.3 square metres surface area, mounted 2500mm above ground level and eccentrically 300mm.

All columns and brackets supplied must be manufactured by a company accredited under the Quality Assurance scheme ISO 9002 and the installer must supply a copy of the appropriate accreditation documentation as part of the record information to be provided.

All columns and brackets shall carry an identification mark which indicates the name of the manufacturer, the year of production and other design information to enable details of the column and bracket to be determined throughout their design life. This information shall be clearly visible after erection of the column.

There shall be no sharp edges within the columns or bracket arms which could damage electrical cables either during installation or while in service. Door openings shall be free from irregularities and burrs. All columns shall be provided with an earthing lug positioned at the bottom left hand side of the base compartment.

The column root shall be pre-treated using Dacrylate paint system to 250mm above ground level.

Positioning of the columns shall be as indicated in Fig1.

Column Doors

A suitable earth connection shall be fitted on all doors.

Doors shall be secured to the column shaft by either:

- a) A minimum 3mm diameter galvanised steel chain or
- b) Galvanised or stainless steel hinges

The door shall be secured by a single captive clamp fixing with two point contact where hinges are used, or twin yoke type clamp (top & bottom) where a chain is used.

The same pattern of door lock is to be common with all other columns installed on site.

Erection of Columns

Columns shall be erected at the back of the footway or at least 0.8 m from the edge of the carriageway, or 1.0m from the kerb in car park parking bays, unless agreed otherwise by the Project Manager.

Installation and erection shall be carried out in compliance with the current edition of the 'Code of Practice for the Erection of Street Lighting Equipment' published by the Association of Street Lighting Contractors with the following amendments: -

- a) Special attention should be given to the orientation of the base compartment doors to ensure wherever practicable that the maintenance operative shall face oncoming traffic as defined in BS EN 40-2:2004 clause 4.3.1.
- b) Special attention shall be paid to the siting of hinged columns to ensure that, within adopted areas, there are adequate clearances for lowering and maintenance access.

Lighting of Pedestrian Crossings

Pedestrian crossing equipment employed should include black/white section poles supporting a yellow globe with a 40W rough service tungsten filament lamp, a 50 watt tungsten halogen lamp, or an LED array and flasher unit.

The crossing should ideally be located centrally between the lighting columns adjacent to the crossing. Where night time use is high then supplementary direct illumination using white light should be considered over the full carpet of the crossing.

Regulations covering Street Lighting Installation

- Highways Act 1980
- The Management of Health and Safety at Work Regulations 1982
- Electricity at Work Regulations 1989
- Traffic Signs Regulations and General Directions 1991



- Disabled Persons Act 1981
- New Roads and Street Works Act 1991
- BS 7671: Regulations for Electrical Installations 2008
- BS 5489: Parts 1 – 10 ‘Code of Practice for Road Lighting’
- BS EN 60598 – 2-3: 1994, Luminaires for Road and Street Lighting
- BS5649: ‘Lighting Columns’
- BS EN 40-2: Lighting Columns 2004
- Department of Environment, Transport and the Regions Departmental Standard BS26/99 – ‘Design of Lighting Columns’

Fig 1

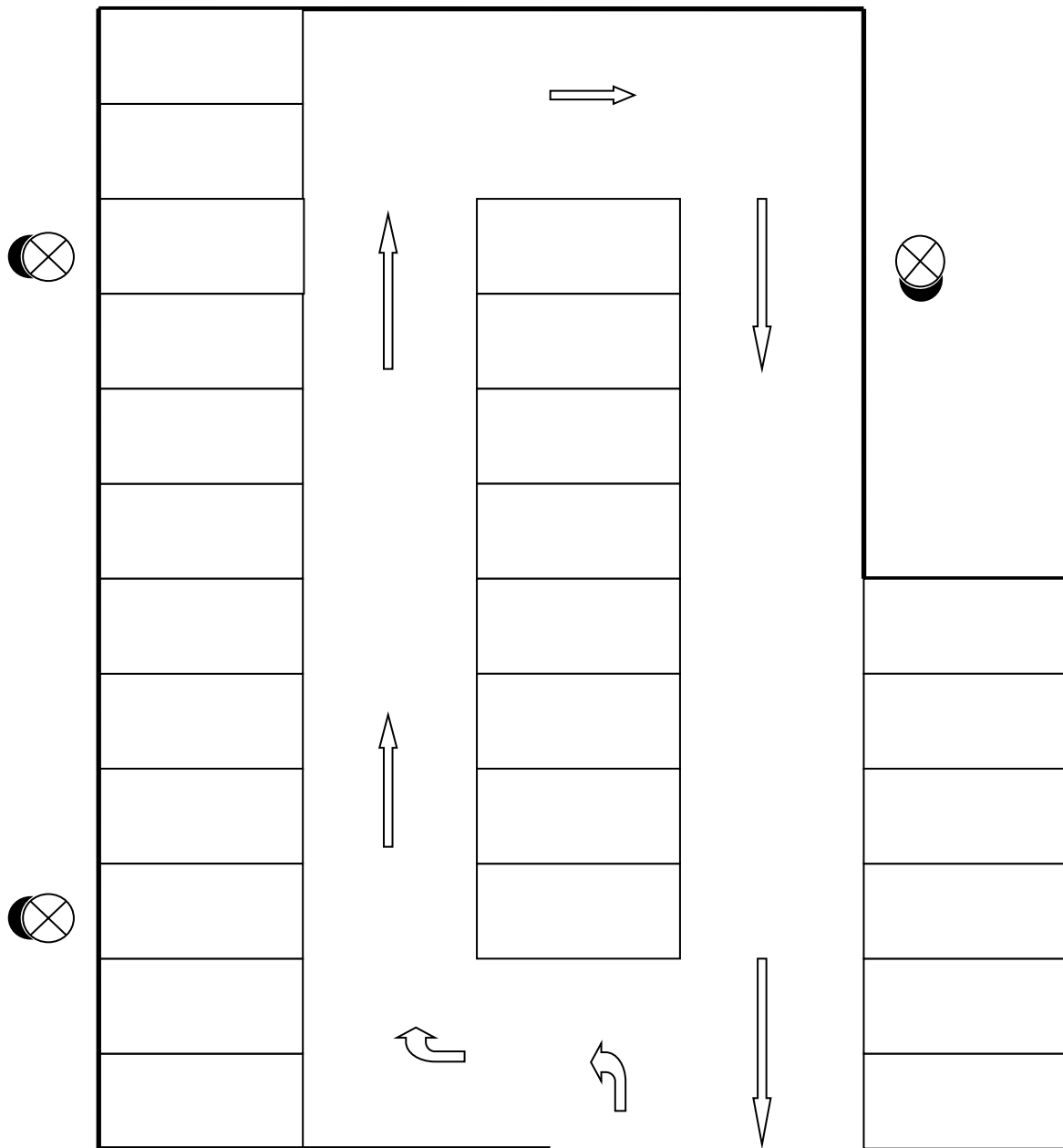

Sketch showing the suggested positioning of street column doors (lighting and signage) in a car park area.



Column



Door position



APPENDIX C – ELECTRICAL NOMENCLATURE (RAL) V2

Approved by: Steve Bigden	Issue Date: January 2019	Review Date: January 2021
-------------------------------------	------------------------------------	-------------------------------------

1 Overview

1.1 This document is designed to make the identification and labelling of Electrical Switchgear and accessories simple and concise, and for this to be uniform across the site infrastructure.

1.2 Clear and unambiguous labelling of switchgear and other equipment is essential for the safe operation of the electrical network. The ability for site staff to cross check both the location and the equipment for each operation is a major factor in reducing the possibility of human error faults.

1.3 In the interests of safety and efficiency, it is essential that any labelling of electrical equipment is carried out carefully and that this takes place at the same time as any change to the network.

2 DISTRIBUTION NETWORKS

Circuit Names and Switchgear Labels

2.1 Labels on HV Switchgear should normally begin with the word 'Feeder' followed by the destination, so '**Feeder to Sub 36,**' or '**Feeder to Transformer T42.**' Where substations sit on a ring, this shall be changed to 'Ring Feeder' with the destination, so: '**Ring Feeder to Sub 9.**'

Any supply that is normally held in reserve (therefore not normally loaded) shall be designated as an 'Interconnector,' so '**Interconnector to Sub 16.**'

Interconnectors can add additional hazards to the safe operation of the network so it is essential that these are clearly labelled.

Labelling shall be fitted at the front of the switch and, where appropriate, at the rear of the switchgear. Cables shall also be identified with labels fixed at the point of the cable entry (see Appendix C3). When fitted, these labels must be confirmed by at least two engineers to ensure they are correctly positioned.

Panel numbering shall commence in both directions from the bus-coupler (where fitted) or from the centre point on symmetrical boards (using the tables in Appendix C1). The bus-coupler will normally be numbered '0' (zero), so '**E0S9**' with panels to the left being odd numbers (1, 3, 5, etc.) and those to the right being even (2, 4, 6, etc.). Where more than one Bus-Coupler exits between incomers, the prime Bus-Coupler shall be numbered '**E0S9A**' with others being labelled in series continuing from '**B**' in the fifth part of the code. Where the Bus-Coupler lays outside the incomers the second part of the code shall follow the normal sequence.

Switchgear with integral isolators and earth switches will have these labelled as independent items, such as '**E5L1**' or '**E5L4**.'

- 2.2 The voltage of a feeder should not be included in the circuit label unless it is necessary to avoid ambiguity as this is included in the numbering system.
- 2.3 The feeder size should not be shown on circuit labels.
- 2.4 Where more than one feeder has the same name then they shall be suffixed with consecutive letters (A, B, C, etc.) so: '**Feeder A to Sub 38**' and '**Feeder B to Sub 38**.' No significance or priority should be given to the 'A' and 'B' designations (these supplies are normally equal). Feeder A should normally be connected to the left portion of the board, Feeder B to the right.

Transformers

- 2.5 Distribution Transformers shall be identified by a number prefixed by 'T,' so **T1 . . . T11 . . . T35 . . . T56**, etc. Although the Transformer's Asset Number will change when a Transformer is replaced, the 'T' number will remain the same. When a Transformer is taken fully out of service (not replaced) the 'T' number will be retired.
- 2.6 The electrical size of the transformer (kVA or MVA) will not be shown on any standard labelling.

Interlocks

- 2.7 Key interlocks (generally Castell type K) shall be used to prevent paralleling of LV supplies, or access to HV enclosures such as VT Chambers and Cast resin Transformer Enclosures.
- 2.8 Key codes need to be agreed with the Authorising Engineer responsible for the equipment, and confirmed by SHE Group who hold the register of all codes used at RAL.
- 2.9 In general, however, LV Interlocks (intakes and bus-coupler) shall be the substation number preceded by an 'S,' so, for example '**S18**.' Where more than one LV board might exist within a substation, the second board code shall have the 'S' follow the number, so '**18S**.'
- 2.10 Access to Cast Resin Transformer Enclosures shall require two Castell Keys: a key released by the HV Feeder once that breaker is closed to Cable Earth; a key released by the LV output ACB once isolated to prevent feedback onto the Transformer (see 2.9). Interlocks on HV Supplies to Transformers shall bear the Transformer number, so '**T14**' for example.
- 2.11 In most cases a key change interlock (to prevent the earth being removed) will be required to release the 'T' key, the code of which will be the substation number

with a sequential letter in the centre starting with A, so '3A8,' '3B8,' etc., including I and O if applicable.

- 2.12 Access to VT Chambers shall be interlocked such that access can only be gained once the HV Breaker is closed to Cable Earth. The interlock shall also prohibit that Earth being released by pressing the 'Off' button on the breaker by the employment of a interlocked cover plate over the button (electrical operation must always be inhibited). VT Chamber interlocks may bear the sequence code described in 2.11, or where the breaker supplies a Transformer, the Transformer code described in 2.10

Rectifiers and Reactors

- 2.13 At present there are no rectifiers or reactors fitted at RAL.

Bus-Bars

- 2.14 When dealing with Bus-Bars at Distribution voltages (11kv and below) apply the rules as detailed in the following 'HV Networks' section.

Cables

- 2.15 A white on black label detailing cables shall be affixed to the point of entry of the cable (cable box or cable way). These labels shall conform to the site standard (see appendix C3) and contain the following information: cable reference; size and number of cores; source or destination.

All Other Plant

- 2.16 Any plant not previously mentioned, along with sealing ends or cable boxes at situations requiring identification from adjacent similar plant shall be labelled with nomenclature of the circuit with which it is associated.

3 HV NETWORKS

General Requirements

- 3.1 All plant in this category shall have labels which have both a description and plant nomenclature.

Circuit Names and Switchgear Labels

- 3.2 Labels shall bear the name(s) of the remote substation (or building in the case of LV distribution). Where there is more than one feeder with the same name, then they shall be suffixed with consecutive letters (see 2.4). The label shall include the correct nomenclature and also include a description of the plant function except

circuit breakers, which will be assumed by default where no other description is given.

Sealing Ends and Cable Boxes

- 3.3 Sealing ends or cable boxes at situations requiring identification from adjacent similar plant shall be labelled with nomenclature of the circuit with which it is associated.

4 NOMENCLATURE

- 4.0 The code used will be a four or five part alpha/numeric in accordance with Appendices 1 and 2.
- 4.1 Part One of the code will denote the operating voltage of the equipment. (Table One)
- 4.2 The Second part of the code will be a number (which maybe greater than nine) denoting the switch groups of any one class within a substation. The sequence used should be selected to best fit the individual site, but should allow for the site to be extended with the minimum amount of label changes (see also 2.1)
- 4.3 It would follow that sites should be labelled from the centre outward with odd numbers one way and even the other. **Spare bays must be assumed as being numbered in accordance with the sequence.**
- 4.4 The Third part of the code denotes the class of equipment as shown in table two.
- 4.5 The Fourth part of the code is shown in table 3 and denotes the function of the switch in the group
- 4.6 Finally the Fifth part of the code shall only be used in circumstances where more than one group of equipment qualifies for a particular number or where we have banked circuits. This final part provides for the appropriate equipment to be suffixed by a letter in sequence starting with "A".

5 LV CIRCUIT LABELLING

- 5.1 The first supply into any building shall be designated as 'D' Supply, unless this causes confusion with circuits in adjoined buildings. In such cases the next lowest designation shall be used where no similar confusion might exist.
- 5.2 Where the supply feeds a switch frame, that frame will be designated as '#,' where # is the designated prefix from D to Z (omitting those listed below). Likewise, if the supply feeds directly on to a distribution board (via an isolator) that



board shall be designated as '#.' No additional numbers shall be added at this point (i.e. D1 would not be appropriate).

- 5.3 The incoming switch or breaker shall be labelled '# Supply,' and likewise any isolator or disconnecting device controlling a distribution board.
- 5.4 All outgoing switches or breakers shall be labelled in a logical order, normally from the top left, as #1, #2, #3, etc. Where outgoing ways are not used, these shall still bear the sequential number ready for future use.
- 5.5 The following prefixes shall be omitted for the stated reasons:
- A** – phase notation
 - B** – phase notation
 - C** – phase notation
 - I** – confusion between I (letter) and 1 (numeral)
 - O** – confusion between O (letter) and 0 (numeral)
 - R** – tap-off reference used on Bus-Bar trunking (for example, if a Bus-Bar trunking were fed from supply D1 and the circuit used the 19th tap-off point, the circuit reference would be D1/R19)
 - T** – looped feed notation 1 (see Fig 1 in Appendix C2)*
 - U** – looped feed notation 2 (see Fig 1 in Appendix C2)
 - V** – looped feed notation 3 (not shown in Fig 1, but acceptable where loadings permit)

***T** designation may be used where this refers to the Transformer Number prefix (replacing D, E, etc.) and is used where numerous supplies to a building are derived directly from a dedicated Substation.

The following prefixes should be avoided wherever possible for the stated reasons:

- L** – line notation (L1, L2, L3) – whilst not used at RAL, there could be confusion with the supply designations L1, L2 and L3 to personnel not fully acquainted with the RAL system. 'L' Supplies which were designated before the issue of the 15th Edition of IET Wiring Regulations have not been changed.

- 5.6 The reference 'DB' for a distribution board shall not be used. This reference could be misconstrued as being the first supply into a building 'D Supply' and being a single phase supply on the 2nd phase (B phase), formerly yellow, now black, or L2.
- 5.7 Figure 1 in Appendix C2 shows a general layout, the solid fuseways indicating circuits in use. Oblique's (/) are used to identify circuit tiers. As an extreme example:

G3/1/3/2/3C/3, where: G3 is the origin; / 1 indicates the second tier is supplied from circuit 1 of board G3; / 3 indicates the third tier is supplied from circuit 3 of board G3/1; 2 indicates the fourth tier is supplied from circuit 2 of board G3/1/3; / 3B indicates that the fifth tier is supplied from the 'C' phase of circuit 3 in board

G3/1/3/2 (single phase); / 3 indicates that the final circuit is fed from circuit 3 of board G3/1/3/2/3C

- 5.8 Phase notations (A, B, & C) shall only be used to indicate single- or two-phase circuits (ie. H7/3B/2 or F4/5/2BC). The lack of phase notation automatically indicates a three-phase supply (therefore E2/2/6ABC is unnecessary and incorrect). Phase notation should only be used once within the circuit reference, thereby indicating where the change occurs, which may not necessarily be at the final circuit.
- 5.9 Where phasing changes at the same point as a looped feed, the phase notation shall always precede the loop designation. Therefore the reference should read J5/4/3BT, or J5/4/3BU, and **not** J5/4/3TB, or J5/4/3UB.

6. ASSET REGISTER (pirana)

- 6.1 In order that we can identify plant for maintenance it is essential that each item of plant within the Pirana system is given a unique identifier. It should be noted that these Asset Codes may bear no resemblance to any of the Nomenclature detailed above.
- 6.2 Even where a Substation is sited within a Building, the Substation number (SS##) shall make up the centre part of the Asset Code for all equipment, thereby making it obvious that access to any such numbered equipment will require at least an Authority for Access.
- 6.3 Where items are replaced the Asset Number will be changed to avoid confusion with the original item, thereby initiating a new history. However, in most cases, the equipment number shall remain the same (for example see 2.5 for Transformers).

Appendix C1

Table 1

Part 1 of the identifier	
A - 132kV	E - 11kV
B - 66kV	F - 6.6kV
C - 33kV	G – 3.3kV
D - 22kV	L – 400V

Table 2

Part 3 of the identifier	
A	Miscellaneous auxiliary equipment, E.G. V.T.'s (HV Side)
H	Transformer high voltage side
L	Line or cable
M	Generator
S	Bus-Coupler Interconnector (within a substation)
T	Transformer Low Voltage Side
V	V.T. LV Isolator

The fourth part of the code is shown in Table 3 and denotes the function of the switch in the group.

Table 3

Part 4 of the identifier	
1	Earthing switch or device
2	By-pass isolator
3	Circuit Isolator



4	Main bus-Bar isolator
5	Circuit breaker (lines) Circuit breaker (2nd choice excluding lines) *Switching Isolator (excluding lines)*
6	Reserve Bus-Bar isolator Mesh opening corner isolator
7	Circuit breaker isolator, Bus-Bar side
8	Main Bus-Bar isolator (2nd choice)
9	Circuit breaker (excluding lines) *Switching Isolator (lines)*
*SWITCHING ISOLATORS: Conventional isolator numbering shall be used where a switchgear isolator is provided primarily as a point of isolation within its requirements of the Safety Rules.	

The fifth part of the code will only be used where more than one item in a group qualifies for a particular number or where banked circuits exist then each number as derived from Tables 1 – 3 will be suffixed by a letter, all such letters shall be in sequence starting at "A".

Appendix C2

Key:
 Blue – switches/frames
 Green – Dist. Boards
 Yellow – Final Circuits

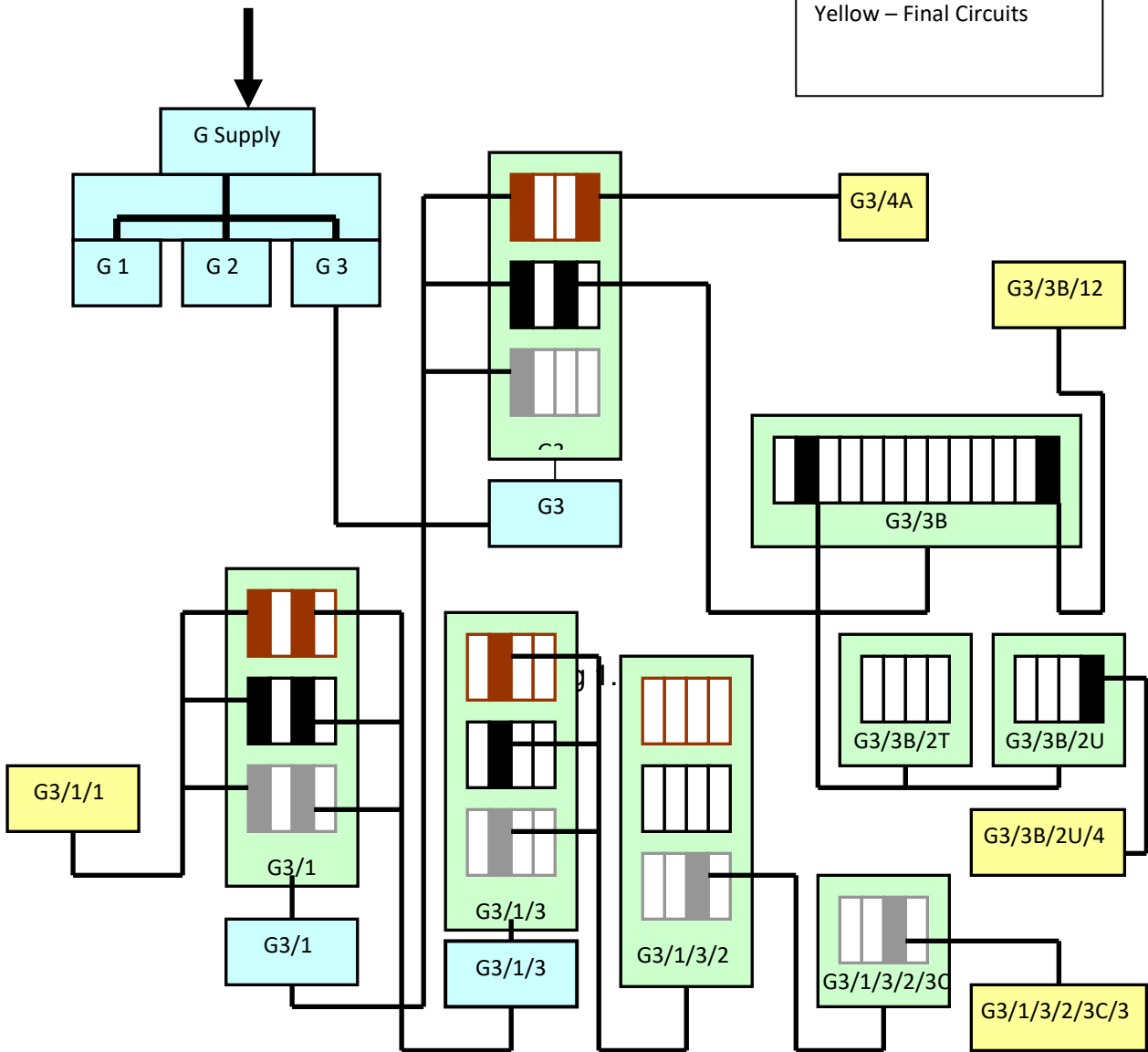

Appendix C3

ELECTRICAL SIGNS:

Format C1 (Cables): 125 x 75mm White on Black c/w 4 x 4.5mm holes

Format C2 (Cables): 100 x 60mm White on Black c/w 4 x 4.5mm holes



Format L10 (Transformers): 150 x 100mm Black on White c/w 4 x 6.5mm holes





APPENDIX D – MANUFACTURERS/SUPPLIERS



General

Product	Manufacturer/Supplier	Example URL.
Inverters	ABB	
	Danfoss	
Vibration Isolation Couplings	Engineering Appliances	
Vibration Isolation Mounting	Industrial Acoustics Ltd	
Security systems	Nacoss Approved	
Gas detection	Crowcon	

Electrical

Product	Manufacturer/Supplier	Example URL.
HV Switchgear	Groupe Schneider (Genie Evo)	
Transformers (Midel)/Cast Resin	Schneider	
Unit Protection	Solkor	
LV Switchpanel	G.E.	
MCCB Panel Boards	Schneider	
Surge Protection	Furse	
Power Factor Correction	ABB	
	G.E.	
Electric Meters (Panel board)	Socomec (Modbus)	
Electric meters (MCB)	Schneider	
UPS units	ABB	
	Riello	
Standby generators	FG Wilson	
	Caterpillar	
Generator controllers	Deep Sea controller/s	
Cable (HV + LV)		
	Doncaster cables	
Cable (Wiring)		
	Doncaster cables	
Distribution Equipment (MCB)	Schneider electric	
Luminaires (General)	Glamox (Luxonic) (LED)	
	Dextra	
External Luminaires	Phillips (LED)	
Road Lighting	Phillips (LED)	
Emergency Luminaires	Glamox (Luxonic) Wireless	
Automatic lighting control	Dali	
Data Cable	Cat 6a	
Fire Alarm Cable	Prysmian FP200 Gold (red)	
Cable Trunking/Tray	Medium grade (no light duty) - Swifts	
Door Access Control Systems	C-Cure Systems (HID)	
Busbar Trunking	Barduct (Siemens)	
BS 4343 sockets	MK Commando	
Accessories	MK Electric	
Isolators	MK Commando	
Dado Trunking	MK Prestige 3D Dado and Skirting	
Fire Alarms	Advanced Fire Alarm systems – Type MX Pro 5 supplied with Touch control interface	
	Apollo protocol ancillaries	
	Discovery Open-area voice sounders	
	Linear heat detection cable – Britain cables	
	Aspiration systems – Air Sense	



Lightning Protection	Furse	
----------------------	-------	--

Mechanical

Product	Manufacturer/Supplier	Example URL.
LTHW Boilers	Remeha	
Steam boilers	Byworth	
Boiler Burners/Combustion	Dunphy Combustion	
	Riello	
Radiators	Stelrad	
	Myson	
TRV's	Danfoss	
Chillers	Airedale (Turbocore)	
Air Conditioning Units (DX)	Toshiba	
	Mitsubishi	
	Daikin	
Trace Heating	Raychem	
Electrically Heated Showers	Kohler Mira	
Thermostatic Mixer Showers	Hansgrohe	http://www.hansgrohe.co.uk
Cold water storage tanks	Dewey Waters	
Humidifiers (resistive)	Neptronic	
Gas humidifiers	Neptronic	
Cold Water Booster sets	Grundfos	
Pressurisation Units/Cold fill sets	Mikrofill 3	
	Flamco PressDS (Pressurisation/Dosing System)	
Fire Dampers	Actionair Ltd	
Constant Volume Devices	CMR Ltd	
Manual Control Dampers	Actionair	
Air Handling Units (Supply and general extract)	Systemair	
	Trane	
	VES	
Fume Cupboard	Cleanair	https://www.cleanairltd.co.uk
Fume Cupboard Extract Fans	Central Fans – Colasit	
	Axair Fans UK Ltd	
Chemical and Fume Extraction and Specialist Fans	Axair Fans UK Ltd	https://www.axair-fans.co.uk
Extract fans	Nu-aire	
Filters	Camfil Farr	
Diffusers, Grilles and Transfer Grilles	Colman Moducel	
	Waterloo	
	Lindab	
Valves (Water, including commissioning, flow regulating and balancing)	Hattersley Newman Hender Ltd	
	Crane	
LPHW, Chilled Water and Heat Recovery Pump Sets	Grundfos	
Cranes - Pillar	Pelloby	
Cranes - Overhead	Pelloby	
Passenger Lift	Kone	http://www.lestercontrols.co.uk
	Otis	
	Thyssen Krupp	
	Gal door operators	



	To be supplied with Lester Control Panel and Windcrest autodialler	
Goods Lift	Kone	http://www.lestercontrols.co.uk/
	Otis	
	Thyssen Krupp	
	Gal door operators To be supplied with Lester Control Panel	
Flexible/Vibration Couplings	Spirax Sarco	http://www.spiraxsarco.com
Deaerators/Dirt Separators	Spirotech	
Extract fans (100mm-150mm)	Vent-axia	
	Xpelair	
Pump Inertia Bases	Industrial Acoustics Ltd	
2 and 3 Port Control Valves 24Vac, 0-10V modulating	Danfoss	
	Belimo	
Safety Valves (Water, Steam, Compressed Air)	Hattersley or Nabic with certificates	
Expansion Bellows	Engineering Appliances	
DHWS Calorifiers and Expansion Vessel	Heatrae Sadia	
Electric/gas water heaters	Heatrae Sadia	
	Andrews	
Pressure Differential Control Valves	Samson Controls	
Fan Coil Units	Ability	
Fan filter units	Envirco	
Thermostatic Mixing Valves	A & J Gummers Ltd	
Heat Exchangers	Alfa Laval	
Support Systems	Big foot	
	Unistrut	
Automatic Air Vents	Spirotech	
Gauges and Instruments	Brannan & Sons	
Meter Monitoring	RDM Kweb through Trend	
Gas Meters	Schlumberger Industries (Modbus)	
Building Management System and controls	Trend	
Pressure Control Devices & Bypass Control Valves	Samson Controls Ltd	
Gas Booster (if required)	Howden Donkin	
Steam fittings/h/x	Spirax Sarco	http://www.spiraxsarco.com
Trench heating	Dunham Bush	
Water Meters	Kent (Modbus)	
Water Softeners	Culligan UK	
Water Purifiers	Culligan UK	
Underfloor heating	Rehau	
	Wirsbo	



APPENDIX E – FIRE SAFETY REQUIREMENTS V.2

Where possibly all fire safety provisions for new buildings and refurbishments of existing buildings should be compatible with those already present on-site. Technological advances in products and system designs should be considered so long as these products and systems are compatible with existing systems. When new systems are proposed the RAL Fire Safety Advisor should be consulted.

Fire safety systems including but not limited to, fire detection and fire alarm systems, fixed fire-fighting system and smoke and heat control and should be subject to the recommendations of BS EN Standard 16763:2917, which specifies the minimum requirements for service providers as well as the competencies, knowledge and skills of their relevant staff charged with planning, design, installation, commissioning, verification, handover or maintenance of fire systems.

Regulation 38 and/or Fire Strategy Document

GENERAL BUILDINGS – BUILT TO APPROVED DOCUMENT B

Regulation 38: Passing on the right fire safety details.

[Regulation 38](#) is a requirement under the Building Regulations for England and Wales to provide fire safety information to the 'responsible person' at the completion of a project, or where the building or extension is first occupied.

Where a building is erected or extended, or has undergone a material change of use, and the Regulatory Reform (Fire Safety) Order 2005 applies to that building or extension, Regulation 38 requires that a package of fire safety information - 'as built' information which records the fire safety design of the building or extension - must be assembled and given to the 'responsible person' for the premises.

The fire safety information provided should include all fire safety design measures in appropriate detail and with sufficient accuracy to assist the responsible person to operate and maintain the building safely.

Fire Alarm and Detection System

All fire alarm installation work will be carried out by 3rd party certified (BAFE) registered companies or those companies who are substantially through the process of achieving such certification.

All installations shall comply with the current British Standard BS 5839:1-1:2017 Fire Detection and Fire Alarm Systems for Buildings – Code of Practice, for the design, installation, commissioning and maintenance of systems in non-domestic premises

In existing buildings, the Contractor shall make due allowance to install new services and remove old services such that fire detection of areas is not compromised. Whenever possible, existing services shall remain in operation and connected to the old fire panel with new services installed nearby, as directed. The Contractor shall employ the use of temporary cabling where necessary to keep existing services in operation prior to the final testing, commissioning and handover of the new installation.

Smoke detectors shall be of the latest designed type with the consideration for the installation and programming of multi sensors, particularly during refurbishment projects where parts of the original building remain occupied during works.

Consideration for the use of other fire detection products and systems should be discussed as part of the overall fire strategy where conventional smoke/heat sensors may not be suitable, these to include:-

- Flame Detectors

-
- High Sensitivity air-sampling smoke detection system Aspiration systems (Air Sense)
 - Beam detection
 - CCTV
 - Linear Heat Detection
 - Intrinsically safe & explosion proof

Fire Alarm Control Panel.

The nominated suppliers for the fire alarm system are as follows:-

- Panel shall be by Advanced Fire Alarm Systems Type MX Pro 5
- Detection shall be Apollo
- The fire alarm and detection system shall incorporate the use of voice-enhanced sounders. Our nominated manufacturer is Apollo and the use of Discovery Open-Area Voice Sounders
- The MX Pro 5 panel shall be supplied and installed with a Touch-10

Specification for Fire Alarm systems using Advanced Fire Alarm Panel and Apollo Discovery Open Area Voice Sounder.

Where sounders/bells are mentioned these are to be replaced with Voice sounders as detailed below:

Voice Sounder specification for Apollo Discovery Open Area voice sounder

Voice sounders shall be supplied with an integral visual indicator (58000-030) where necessary to meet DDA.

This is the proposal for the activation of the voice sounders under the various scenarios which will need to be developed with the fire alarm cause and effect.

1. On a full fire activation the fire system should use tone /message number M1
2. When the system is reset after a fire activation the fire system should use M2
3. When the fire system is in test mode the use tone/message number M5
4. When the fire alarm system has completed its testing use tone/message M4

Fire Zone Plan

For all new buildings a fire zone plan must be provided as recommended in BS 5839 adjacent to the fire panel or in close proximity. Where there are any refurbishment works or an extension to buildings then the fire zone plan must be checked and any change in configuration of the fire alarm system reflected in the zone plan provided.

Manual call points

Manual call points should comply with the requirements of BS5839-1:2017 where is it proposed for all manual call points to meet the requirements of a type B, e.g. fitted with a protective cover.

All manual call points to be identical unless there is a special reason for differentiation.

Void Detection

If the fire alarm system category or the Fire Risk Assessment requires automatic fire detection in voids then following installation of the detection system a remote indicator should be fitted to ceiling level to identify the detector activation.

Fixed Fire Protection Systems

It is recommended that consideration be given to the provision of fixed fire protection systems at building design stage. An installed automatic fire-fighting system can be a highly effective element in the fire protection strategy, because it is immediately available and designed specifically to meet the defined fire hazard.

Such systems include automatic:-

Sprinkler
Water-spray
Water mist
Gaseous
Foam
Powder
Hypoxic Air fire prevention systems

Active fire-fighting systems need to be reliable and the design of the system should demonstrate this. The design of fire-fighting systems should conform to specified standards such as BS 5306 Code of Practice for extinguishing installation and equipment.

Consideration for use of these fixed fire protection systems

- As well as property protection these systems also offer life safety provision and where fire engineered solutions are required, such systems can be used as a compensatory feature for issues such as extended travel distances, compartmentalisation and other applications.
- They are designed to contain the fire to the room of origin thus saving enormous expense of reconstruction/refurbishment of an entire building or a large part of that building.
- Fire service cuts both in crew numbers and available fire appliances has reduced over the years which means the initial attack may not be carried out until adequate resources are in attendance, indeed Fire Brigade response times have been gradually getting longer.
- Organisational Risk – loss of any of our strategic science and technological facilities would have detrimental effect on the Organisations reputation as well as business/research continuity.

Fume Cupboards

Where there is significant research with experiments involving the use of flammable liquids and/or gases, the installation of local application extinguishing systems should be considered. These systems can be

automatic or manual in which a fixed supply of a fire-fighting medium is permanently connected to fixed piping with nozzles arranged to discharge the fire-fighting medium directly to a fire occurring within the fume cupboard.

A recommended product would be that supplied by Firetrace, however, there are other companies who manufacture similar products.

Refuge Areas

Refuges are relatively safe waiting areas for short periods. They are not areas where disabled people should be left alone indefinitely until rescued by the fire and rescue service, or until the fire is extinguished.

In general, under the Building Regulations, a refuge should be provided for each protected stairway affording egress from each storey, except storeys consisting exclusively of plant.

To facilitate the effective evacuation of people from refuges an emergency voice communication (EVC) system connected, using the appropriate method, to the main RAL security building should be provided. It is essential that the occupants of each refuge are able to alert other people that they are in need of assistance and for them to be reassured that this assistance will be forthcoming. The EVC system should comply with the current edition of BS 5839: Part 9

Such systems are subject to a high standard of design manufacture, installation, commissioning and maintenance, similar to those covering fire detection and fire alarm systems.

To ensure consistency for all new building it is recommend the EVC system provided in the **R100** building be adopted across the site.

Revolving and Automatic Doors

Revolving doors, automatic doors and turnstiles can obstruct the passage of persons escaping. Accordingly, they should not be placed across escape routes unless:

- a) They are to be the required width and are automatic doors and either:
 - i. Are arranged to fail safely outward opening from any position of opening; or
 - ii. Are provided with monitored fail safe system for opening the doors if the mains supply fails; or
 - iii. They fail safe to the open position in the event of power failure; or
- b) Non-automatic swing doors of the required width are provided immediately adjacent to the revolving or automatic door or turnstile.

Automatic Door Release Mechanisms/Hold Open Devices for Self-Closing Fire Doors

Where self-closing fire doors may cause serious restriction in the free movement of people within a building, consideration must be given to install where appropriate use of automatic door release mechanisms. Provision of such a system prevents occupants from wedging doors in the open position.

The following criteria should be appropriately applied: -

- 1) The door release mechanism should conform to an appropriate standard.
- 2) All doors fitted with automatic releases should be actuated by an appropriate automatic fire detection and alarm system. BS 5839 details an acceptable standard.
- 3) If devices are fitted to fire doors protecting the means of escape then the automatic detectors should be positioned in accordance with British Standard 5939 part 1, for a Type L3 system as a minimum i.e. suitable detector on the means of escape routes and in adjacent rooms opening onto these routes. It is recommended all escape routes be fitted with smoke detectors.

Access Control /Building Management System

All electromagnetic and electromechanical locks and latches that are used to secure emergency exit or which are found on routes of escape must fail safe (i.e. the lock will be disengaged) the power supply fails or is withdrawn.

Additionally where the premises are fitted with a fire alarm system, which is in most cases, any activation (whether initiated via a call-point or by an automatic detection device) will, through the interfacing of relevant systems, ensure that power is withdrawn from the access control locking devices, thus releasing them and allowing unimpeded exit.

Fire Exit Escape Route Signage

An escape route signing system should ensure that from any place within a building, where direct sight of an exit is not possible and doubt might exist as to its position, a directional sign (or series of signs) is provided. Signs should be placed so that the person moving within the means of escape is progressed toward the final exit and all signing systems should be clear so that they minimise the risk of confusion.

All escape route signs should be adequately illuminated to ensure they are conspicuous and legible within the environment. All escape route signs should be visible under power loss conditions. It may be appropriate in some premises that a maintained light source is provided or the same objective can be achieved with photo luminescent escape route signage.

Guidance on the application and siting of means of escape signs is given in BS 5499: Part 4.

Emergency Escape Lighting

In the event of a failure of the supply to the normal lighting, emergency escape lighting should be available to assist occupants to evacuate a building safely by: -

- a) Locate and identifying exit signs at doors and escape routes direction signs ;
- b) Using escape routes
- c) Conducting safety measures prior to evacuation, such as shutting equipment down safely or checking that all personnel have vacated the premises (STFC - Building Wardens)

The duration of the emergency escape lighting should include time to evacuate disabled occupants or to release anyone trapped in a lift.

Guidance on the application of Emergency Lighting is contained within the British Standards 5266 suite of Codes of Practice.

Sounders

The following sounders are currently fitted at each site:-

- | | |
|-----------------------------------|-----------------------|
| 1. Rutherford Appleton Laboratory | - Bells |
| 2. Chilbolton | - Electronic sounders |
| 3. Electron building (R97) | - Electronic sounders |
| 4. The Coseners House | - Bells |
| 5. ATC Edinburgh | - Bells |
| 6. Daresbury | - Bells |
| 7. Ridgeway House | - Bells |

All sounder devices must be numbered in accordance with STFC standards.

Flashing Beacons (External existing buildings)

Beacons augmented by notices are to be provided at all entrances/exits to the building. Their purpose is to inform persons approaching the building that the fire alarm is activating and not to enter.

Recommended device is Hochiki wall sounder beacon suitable for external mounting. The sounder element of the system is to be programmed not to operate.

Flammable gas

Where it proposed for flammable gases to be used within building e.g. acetylene, hydrogen, methane etc., then the gas cylinders must be located external to the building, in a secure ventilated compound and piped in with automatic shut-off valves interfaced with the fire alarm system.